

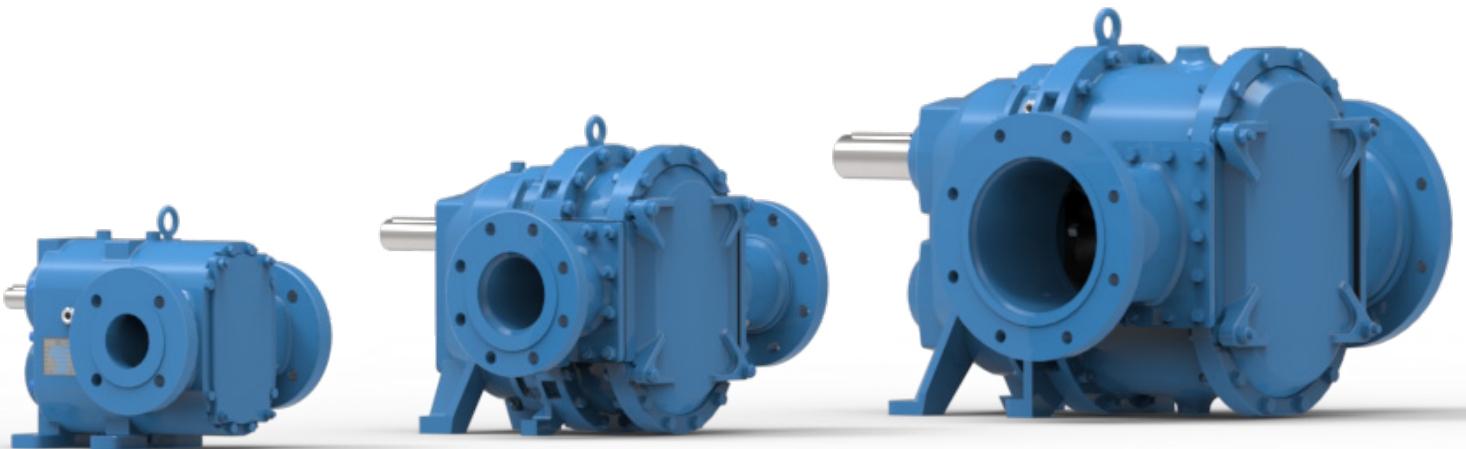

LOBEPRO

ROTARY PUMPS

INSTALLATION AND MAINTENANCE MANUAL



2610 Sidney Lanier Drive, Brunswick, Georgia 31525
Toll Free: 1-888-997-PUMP (7867) • Tel: (912) 466-0304 • Fax: (912) 466-0086

For more info, visit us at www.lobepro.com or email info@lobepro.com

Revision 13 - 1 MAY 2026

Table of Contents

- Certificate of Conformance: CE Designation -5**
- ISO 9001: 20015 Certification..... -7**
- Terms and Conditions of Sale -9**
- Warranty Terms -10**
- Warranty Activation..... -11**
- Pump Exchange Program and Remanufactured Pumps..... -12**
- 1 USER SAFETY -12**
 - 1.1 Safety Terminology and Symbols -14
 - 1.2 Important Safety Instructions and Warnings -14
 - 1.2.1 General Safety Instructions..... -15
 - 1.2.2 Pump Safety Instructions -15
 - 1.2.3 Electrical Drive Safety Instructions -16
 - 1.2.4 Gas/Diesel Engine Pump Drives -16
 - 1.2.5 Hydraulic Pump Drives..... -16
 - 1.2.6 Explosion Proof Environments -17
 - ATEX Explosion Proof Environment Use..... -17
 - 1.3 Scope of Compliance -18
 - 1.4 Preventing Build-up of Explosive Mixtures in the Pump..... -18
 - 1.5 Preventing Sparks..... -18
 - 1.6 Preventing Leakages..... -19
 - 1.7 Maintenance to Avoid Hazards -19
 - 1.8 Environmental Safety -19
 - 1.9 User Safety -20
 - 1.9.1 General Safety Rules -20
 - 1.9.2 Safety Equipment..... -20
 - 1.9.3 Personnel Training..... -20
- 2 LOBEPRO PUMP IDENTIFICATION -21**
 - 2.1 LobePro Pump Serial Nameplate -21
 - 2.2 LobePro Pump Model..... -22
 - 2.3 Baseplate ID -23
- 3 LOBEPRO PUMP BASICS AND OPERATION..... -24**
 - 3.1 General Pump Description -24
 - 3.1.1 Typical Uses and Applications..... -24
 - 3.1.2 Solids and Viscosity Handling -24
 - 3.1.3 Operation and Performance -24
 - 3.2 Direction of Rotation and Flow -25
 - 3.3 Direction of Flow and Drive Configuration..... -25
 - 3.4 Start-up and Priming..... -26
 - 3.5 Process Advisories..... -27
 - 3.5.1 Solids Handling -27
 - 3.5.2 Thick/Viscous Fluid Handling -27
 - 3.5.3 Other Process Slurries and Multi-phase Process Fluids -27
 - 3.5.4 Wellpoint Applications..... -28
 - 3.5.5 Operation in Adverse Temperature Conditions..... -28
 - 3.6 Recommended Controls -28
- 4 SHIPPING, HANDLING, AND STORAGE..... -30**
 - 4.1 Packaging and Shipping -30
 - 4.2 Receiving and Handling -30
 - 4.3 Storage Requirements -31
 - 4.3.1 Temporary/Short Term Storage -32
 - 4.3.2 Long Term Storage -32
 - 4.3.3 Cold Weather Storage -33

5 INSTALLATION AND COMMISSIONING	-34
5.1 Location and Clearances.....	-34
5.2 Alignment and Mounting.....	-34
5.2.1 Alignment Methods.....	-35
5.3 Commissioning and Start-up.....	-35
5.3.1 Pre-Commissioning Procedures.....	-35
5.3.2 Commissioning Procedures.....	-36
6 TYPICAL CONFIGURATIONS	-37
7 PIPING SYSTEMS.....	-39
8 LUBRICATION GUIDE	-40
8.1 Standard Lubricants.....	-40
8.2 Oil Inspection.....	-40
8.3 Filling and Draining the Oil.....	-40
8.4 Lubrication Volumes.....	-42
8.5 Maintenance Frequency.....	-42
8.6 Causes of Contamination.....	-43
8.7 Flushing after Contamination.....	-43
8.8 Cleaning and Replacing Bearing Grease (Lh-frame Only).....	-44
9 MAINTENANCE TOOLS & KITS.....	-45
9.1 Recommended Standard Tools for Maintenance.....	-45
9.2 LobePro Toolkits.....	-47
9.2.1 S-frame Tool Box.....	-47
9.2.2 M-frame Tool Box.....	-48
9.2.3 L-frame Tool Box.....	-49
9.2.4 Lh-frame Tool Box.....	-50
10 PUMP MAINTENANCE GUIDE	-51
10.1 Pump Disassembly.....	-51
10.1.1 Removing the Pump Cover.....	-51
10.1.2 Removing the Cover (No-hole) Wear Plate.....	-52
10.1.3 Removing the Lobes.....	-52
10.1.4 Removing the Quench Chamber (Shaft Hole) Wear Plate.....	-55
10.1.5 Removing the Mechanical Seal Assemblies.....	-56
10.2 Pump Reassembly.....	-59
10.2.1 Installing the Mechanical Seal Assemblies.....	-59
10.2.2 Installing the Lobes.....	-63
10.2.3 Installing the Pump Cover and Cover Wear Plate.....	-67
10.3 Lh-frame High Pressure Door Assembly.....	-69
10.3.1 Removing the High Pressure Door Assembly.....	-69
10.3.2 Installing the High Pressure Door Assembly.....	-72
10.4 Rebuilding the Mechanical Seal Assembly.....	-77
10.4.1 When to Replace Mechanical Face Seals.....	-78
10.5 Pressure Testing the Mechanical Seals.....	-79
10.6 Adjusting the Housing Segments & Lobe Clearances.....	-80
10.7 Reinstalling the Transition Fittings.....	-83
11 TROUBLESHOOTING.....	-84
12 LARS SEAL TROUBLESHOOTING GUIDE.....	-86

EU DECLARATION OF INCORPORATION WITH COUNCIL DIRECTIVE 2006/42/EC			
Issue Details:	Date:	Place:	Dol Number:
Directive:	Machinery Safety Directive 2006/42/EC		
Conforming Machinery:	LOBEPRO - ROTARY LOBE PUMPS		
Model Number:			
Serial Number:			
Manufacturer:	LobePro, LLC 2610 Sidney Lanier Drive Brunswick GA 31525 USA		
Authorised Representative, where appropriate:	Mr. David Waite, 33 Denham Lane, Chalfont St. Peter Gerrards Cross, Buckinghamshire SL9 0EP, England		
Harmonised Standards & Other Technical Standards/Specifications Applied or Referenced:	EN 809:1998 + A1:2009		
Essential Requirements of this Directive Applied:	Essential Health and Safety Requirements of Annex 1 of the Machinery Directive		
Technical Documentation:	The Technical Documentation is compiled in accordance with Part B of Annex VII. The manufacturer will transmit any relevant information on the partly completed machinery requested by a national authority. This information/documentation will be transmitted by the following means: Insert Means Here e.g. CD/Data Disc		
We hereby declare that the partly assembled machinery described above must not be put into service until the final machinery into which it is to be incorporated has been declared in conformity with the provisions of Council Directive 2006/42/EC on the approximation of the laws of the Member States relating to the safety of machinery.			
Signed:			
Signatory:	Diane H. Brock, President		



CERTIFICATE



This is to certify that

LobePro LLC

2610 Sidney Lanier Dr
Brunswick, GA 31525
United States of America

has implemented and maintains a **Quality Management System**.

Scope:

The design and manufacture of rotary and submersible pumps and pump systems, under the name of LobePro.

Through an audit, documented in a report, it was verified that the management system fulfills the requirements of the following standard:

ISO 9001 : 2015

Certificate registration no.	10005463 QM15
Date of original certification	2009-04-17
Date of revision	2025-03-27
Date of certification	2024-01-02
Valid until	2027-03-01



DQS Inc.

David Tellez
Managing Director

DQS IS A MEMBER OF



Accredited Body: DQS Inc., 1500 McConnor Parkway, Suite 400, Schaumburg, IL 60173 USA
The validity of the certification can only be verified by the QR-code.

Terms and Conditions of Sale

REVISED 1 MAY 2026

OUR ACCEPTANCE OF YOUR ORDER IS EXPRESSLY CONDITIONED ON THE GENERAL TERMS AND CONDITIONS SET FORTH BELOW AND ALL TERMS STATED ON THE FACE OF THIS FORM. THE CONTRACT SHALL NOT INCLUDE ANY DEVIATING OR ADDITIONAL TERMS UNLESS EXPRESSLY AGREED TO IN WRITING AND SIGNED BY AN OFFICER OF OUR COMPANY. YOUR ACCEPTANCE OF ANY GOODS SUPPLIED BY US, OR ON OUR BEHALF, SHALL, WITHOUT LIMITATION, CONSTITUTE ACCEPTANCE OF ALL TERMS AND CONDITIONS STATED ABOVE AND IN THE ATTACHED WARRANTY POLICY.

PRICES: All prices are subject to change without notice and all shipments will be invoiced at the price in effect at the time of shipment, except when otherwise agreed to in writing by our authorized representative. Published prices are for products of our standard design and construction and any item not covered by the most recent published price list must be referred to us for special pricing. Prices are FOB Brunswick, GA and do not include packing, freight, or transit insurance. Weights shown in our price list are approximate shipping weights. The tax and other government charges are not included in the price and will be added to billing unless you provide us with an appropriate exemption certificate.

QUOTATIONS: Prices quotes by us are valid for 30 days from date of quotation unless we have otherwise specified in writing. Clerical errors on quotations are subject to our correction and such errors will not be binding. If drawings are requested and received by the customer for a complete system but only a bareshaft pump is purchased, then an Engineering Service Fee will be invoiced to the customer. For details, please see "Design and Engineering Services."

CANCELLATIONS AND REVISIONS: No purchase orders accepted and acknowledged by us may be cancelled or revised by you except with our prior written consent and upon payment of reasonable cancellation charges compensating us for all costs incurred in work done and material purchased. We reserve the right to determine what constitutes reasonable cancellation charges. See chart below for standard terms.

Standard Cancellation Terms	
Milestone/Activity	Cancellation Fee
After Receipt Of Preliminary Submittals	15% of order
After Receipt Of Customer Approved Drawings For Manufacture/Fabrication	20% of order
After LobePro Order Of Buyout Items	50% of order
After Assembly/Manufacture of Order	75% of order
After Complete Delivery Of Order	85% of order

CREDIT AND PAYMENT: Unless otherwise agreed, a deposit of 50% is required to secure the order. The balance of the order is due before shipment. Overdue accounts are subject to a service charge. All orders are subject to approval by our credit department. Pro-rated payments shall become due as shipments are made. If the shipments are delayed by you for any cause, payments shall become due from the date on which we are prepared to make shipment and storage shall be at your risk and expense. If manufacture is delayed by you for any cause, a partial payment based upon the proportion of the order completed shall become due from the date on which we are notified of the delay.

DESIGN AND ENGINEERING SERVICES: Upon request, LobePro will provide drawings and specifications for standard pump packages including the skid/baseplate, gear reducer, guarding, and coupling or other similar assembly. This service is free of charge unless the customer subsequently purchases only a bareshaft pump. If only a bareshaft pump is purchased, an Engineering Service Fee of \$500 per design package will be charged, plus \$125 per engineering hour in excess of 4 hours for modification of the standard package if applicable.

SECURITY INTEREST: We shall have a lien on all goods sold as security for payment on the invoice price, and upon request by you shall provide and execute a financing statement showing such lien.

DELIVERY: We will make reasonable effort to meet your delivery requirement when you provide us, on a timely basis, all approvals, technical data, instructions, and credit approval requirements needed for the release of the shipment. However, all delivery and/or shipment dates are estimates only unless we expressly guarantee such dates in writing, at your specific request. In no event shall we have any liability if delivery is delayed by strikes, labor disturbances, material shortages, plant calamities or disasters, acts of God, government actions, civil disturbances, the failure of any pre-supposed conditions of the contract, withholding shipments due to credit clearance, or other interferences beyond our control. The date of delivery shall be extended for a period of time equal to the time lost because of any such reason. For emergency and rush orders, contact the Sales Department for applicable fees.

SHIPPING: Unless you specify in writing and we acknowledge in writing, (A) goods will be boxed or crated as we deem appropriate for protection against normal handling and for domestic transit, (B) routing and manner of shipment will be at our discretion, and may be insured at your expense. An extra charge will be made for special handling. All shipments are FOB point of manufacture. Delivery of goods to the initial carrier will constitute delivery to you and all goods will be shipped at your risk. A claim for loss or damage in transit must be entered with the carrier and prosecuted by you. Acceptance of material from a common carrier constitutes a waiver of any claims against us for delay, damage, or loss.

LIMITED WARRANTY: Our warranty policy entitled "Warranty Terms" issued 1 May 2026 is attached and is part of the Terms and Conditions of your order. This document explains our warranty policy in detail. GOVERNING LAW: It is understood and agreed that these Terms and Conditions of Sale shall be interpreted under and pursuant to the laws of the State of Georgia; you agree that any action at law or suit which is related to any contract of sale brought against us shall be filed in a federal or state court located in the State of Georgia.

RETURN OF NEW EQUIPMENT: No equipment shall be returned to us without first obtaining a written "Return Materials Authorization" (RMA) and shipping instructions from us. Credit may be allowed for new, undamaged equipment of current standard design at 80% of the invoiced price or current billing price, whichever is less. Equipment which has been used, however slight, will not be accepted. Authorization will not be given for new equipment (1) which would, in our opinion, result in an excess in the amount of stock we normally carry, (2) not invoiced within the last 12 months, or (3) which is non-standard and manufactured specifically to a buyer's specifications. For non-standard equipment which is not of our manufacture, the only credit allowed will be such credit as may be allowed by the manufacturer of such equipment. Equipment must be returned within 60 days of the issuance of the Return Materials Authorization. No item with a net value of less than \$35.00 USD will be authorized for return. Items not available for return are those items with a shelf life and hardware items. Unauthorized material returns may be refused and/or returned freight collect. The returning party must prepay the charges in full for transportation to our factory.

PHOTOGRAPH USAGE: Unless otherwise notified by purchaser, LobePro reserves the right to use installation photographs taken by LobePro employees or submitted by customers in its marketing materials.

Warranty Terms

REVISED 1 MAY 2026

WORKMANSHIP WARRANTY: We warrant to our immediate customer and to the ultimate customer that LobePro brand products of our manufacture will be free of defects in material and workmanship under normal use and service for two years from the date of installation or 30 months from the date of shipment, whichever occurs first, when installed in accordance with LobePro instructions. This includes all pumps and replacement parts. Such failures are ordinarily evident in the first 30 days of operation and may include gear noise, excessive vibration, or lobe delamination. Such problems are rare as each pump is factory tested prior to shipment. The workmanship warranty does not replace parts that have been damaged due to wear.

LIMITED WARRANTY: LobePro, LLC Seller warrants that the supplied rotary lobe pump will be free from defects in materials and workmanship under normal use for a period of 18 months from the date of shipment. This limited warranty does not cover damage or failure resulting from normal wear and tear, routine maintenance items, corrosion, erosion, improper installation, misuse, abuse, accident, chemical attack, electrical faults, or unauthorized repair or modification. All warranty claims must be submitted in writing within thirty (30) days of discovery and must include proof of purchase, installation, commissioning and startup records, and operating data of the pump at least 24 hours prior to discovery. No other warranties, express or implied, including merchantability or fitness for a particular purpose, are made.

GENERAL WARRANTY INFORMATION

The "ultimate customer" is defined as the purchaser who first uses the product after its initial installation or, in the case of products designed for nonpermanent installation, the first owner who used the product. It is the purchaser's or any sub-vendee's obligation to make known to the ultimate customer the terms and conditions of this warranty.

This warranty gives you specific legal rights, and there may also be other rights which vary from state to state and country to country. In the event that the product is covered by the Federal Consumer Product Warranties Law, (1) the duration of any implied warranties associated with the product by virtue of this law is limited to the same duration as stated herein, (2) this is a LIMITED WARRANTY, and (3) no claims of any nature whatsoever shall be made against us, until the ultimate customer, his successor, or assignee notifies us in writing of the defect, and delivers the product and/or defective part(s), freight prepaid, to our factory or nearest authorized service station. In states or countries that do not allow limitations on the length of an implied warranty, the above limitation does not apply.

THE SOLE AND EXCLUSIVE REMEDY FOR BREACH OF ANY AND ALL WARRANTIES WITH RESPECT TO ANY PRODUCT SHALL BE TO REPLACE OR REPAIR AT OUR ELECTION, FOB POINT OF MANUFACTURE OR AUTHORIZED REPAIR STATION, SUCH PRODUCTS AND/OR PARTS AS PROVEN DEFECTIVE. THERE SHALL BE NO FURTHER LIABILITY, WHETHER BASED ON WARRANTY, NEGLIGENCE, OR OTHERWISE.

Performance warranties, valid up to 30 days, must be issued in writing by a LobePro employee to be considered binding. Warranties are void if the information provided to LobePro is materially incorrect. Due to inaccuracies in field testing, if a conflict arises between the results of a field test conducted by or for the ultimate customer and our laboratory test (which may be corrected for field performance), the latter shall control. Components or accessories supplied by us but manufactured by others are warranted only to the extent of and by the terms and conditions of the original manufacturer's warranty.

RECOMMENDATIONS FOR SPECIAL APPLICATIONS OR THOSE RESULTING FROM SYSTEM ANALYSES AND EVALUATIONS WE CONDUCT WILL BE BASED ON OUR BEST AVAILABLE EXPERIENCE AND PUBLISHED INDUSTRY INFORMATION. SUCH RECOMMENDATIONS DO NOT CONSTITUTE A WARRANTY OF SATISFACTORY PERFORMANCE AND NO SUCH WARRANTY IS GIVEN.

This warranty shall not apply when damage is caused by (A) improper installation or operation, (B) improper voltage, (C) lightning, (D) sand or other abrasive materials (unless use in this application has been approved in writing by us – see above), (E) scale or corrosion build-up due to excessive chemical content. Any modification of the original equipment will also void the warranty. We will not accept charges incurred by others without our prior written consent.

This warranty is void if our inspection reveals the product was used in a manner inconsistent with normal industry practice and/or our specific recommendations. The purchaser is responsible for communication of all necessary information regarding the application and use of this product.

No rights extended under this warranty shall be assigned to any other person, whether by operation of law or otherwise, without our prior written approval.

If any litigation is commenced between the parties hereto for the enforcement of any rights hereunder, the successful party in subject litigation shall be entitled to receive from the unsuccessful party all costs incurred in connection therewith, including a reasonable amount for attorney's fees.

Warranty Activation

LobePro strives to supply pumps and equipment of the highest quality and stands behind each pump sold; however, we can only guarantee performance when the pump is maintained and operated in accordance with the procedures of our Installation and Maintenance Manual and as approved by LobePro. In order to verify that the pump is stored, maintained, and operated accordingly, each user/operator shall complete the following forms and return a completed copy to LobePro in order to activate warranty.

LobePro Record of Receipt

LobePro Installation and Commissioning Record

Recommended Service Log and Schedule

LOBEPRO RECORD OF RECEIPT

End User / Operator: _____
 Location: _____
 Reference LobePro Order No.: _____

Pump ID: _____
 Pump Serial No.: _____
 Baseplate Serial No.: _____ N/A, Pump only

INSPECTION AND RECEIVING

Pump and equipment free from signs of damage or improper handling
 Packaging and precautions removed from pump, if ready for immediate installation N/A
 Oil inside all pump and equipment sight glasses, if provided
 Pump shall be able to be rotated with stop wrench or similar device

STORAGE (CHECK ALL THAT APPLY)

Pump will be installed and commissioned immediately
 Pump will be stored indoors, within a temperature range of 32 and 104 °F (0 and 40 °C)
 Pump will be stored outdoors, with an ambient temperature range of _____ to _____ °F / _____ °C
 Pump will be stored for a period of _____ days weeks months
 Pump will be maintained in accordance with LobePro procedures outlined in the user manual

EXPECTED DATE OF COMMISSIONING: _____
LOBEPRO REPRESENTATIVE REQUESTED: Yes, _____ days (Quote will be provided by LobePro) No

APPROVED: _____ Date: _____

RECORD OF RECEIPT MUST BE RECEIVED WITHIN 60 DAYS OF RECEIPT OF SHIPMENT TO ACTIVATE WARRANTY

RETURN THIS FORM TO LOBEPRO TO ACTIVATE YOUR WARRANTY:
 LobePro, Inc. Fax: (312) 468-0888
 2023 Sidney Lane Dr.
 Brunswick, GA 31525
 Attn: Customer Service Email: part@lobepro.com

LOBEPRO INSTALLATION AND COMMISSIONING RECORD

End User / Operator: _____
 Location: _____
 Reference LobePro Order No.: _____

Pump ID: _____
 Pump Serial No.: _____
 Baseplate Serial No.: _____ N/A, Pump only

COMMISSIONING PRE-INSPECTION

Baseplate anchor/mounting bolts securely fastened
 Coupling/shaft alignment inspected and within manufacturer tolerances
 Pump and equipment mounting bolts securely fastened
 Coupling/belt guard in place and securely fastened
 Suction and discharge connections tightened with no visible pipe strain
 Piping is free from blockages and obstructions
 All suction and discharge valves are open
 Drive direction of rotation verified
 Shutdown control (manual or automatic) are in place and functional

COMMISSIONING INSPECTION

Pump meets performance expectations (flow rate, pressure, power, etc.)
 Suction and discharge pressure stable throughout operation
 Pump, driver, and other equipment shows no sign of failure
 No excessive noise throughout start-up, operation, and shutdown
 No excessive vibration throughout start-up, operation, and shutdown
 No signs of oil contamination visible from pump tight gaskets

Date	Time	Flow Rate	Pressure		Input Power		Notes, dB(A)
			Suction	Discharge	Amps	VOL	

APPROVED: _____ Date: _____

RECORD OF RECEIPT MUST BE RECEIVED WITHIN 30 DAYS OF COMMISSIONING TO ACTIVATE WARRANTY

LOBEPRO RECOMMENDED SERVICE LOG

Complete this form each time a step of the Commissioning and Service Schedule (on back) is completed. As a minimum, the pump should be inspected every two months or as recommended by LobePro for your application.

End User / Operator: _____
 Location: _____
 Pump Serial No.: _____

Total Operating Hours: _____
 Date of Last Inspection: _____ Signed Operating Hours: _____
 Date of Last Oil Change: _____ Signed Operating Hours: _____

SEAL QUENCH CHAMBER

Shows no signs of contamination (check every 200 operating hours)
 Flushed and refilled after exceeding 1000 operating hours since last change
 Flushed and refilled due to contamination (pressure test recommended, Section 10.5)

BEARING AND GEAR HOUSING

Shows no signs of contamination (check every 200 operating hours)
 Pump, driver, and other equipment shows no signs of failure
 No excessive noise witnessed
 No excessive vibration witnessed

OPERATION

Suction and discharge pressure stable throughout operation
 Pump, driver, and other equipment shows no signs of failure
 No excessive noise witnessed
 No excessive vibration witnessed

Date	Time	Flow Rate	Pressure		Input Power		Notes, dB(A)
			Suction	Discharge	Amps	VOL	

INSPECTED BY: _____ Date: _____

Make additional copies as necessary

PROCESS DESCRIPTION

Fluid/Process Description	Per Order Specification	Actual
Vapor Pressure	psig	psig
Percent Solids (wt%)	%	%
Pipe Size	in	in
Operating Speed	rpm	rpm
Motor/Driver Power	hp	hp

PRIMARY DUTY POINT

Parameter	psig	psig
Differential Pressure	psig	psig
Discharge Pressure	psig	psig
Suction Pressure	psig	psig
Design Flow Rate	gpm	gpm

SECONDARY DUTY POINT

Parameter	psig	psig
Differential Pressure	psig	psig
Discharge Pressure	psig	psig
Suction Pressure	psig	psig
Design Flow Rate	gpm	gpm

APPROVED: _____ Date: _____

RETURN THIS FORM TO LOBEPRO TO ACTIVATE YOUR WARRANTY:
 LobePro, Inc. Fax: (312) 468-0888
 2023 Sidney Lane Dr.
 Brunswick, GA 31525
 Attn: Customer Service Email: part@lobepro.com

LobePro Commissioning and Service Schedule

Task	Before and after prolonged inactivity	Visible oil contamination	Every 1,000 operating hours	Every 500 operating hours	Every 200 operating hours	24 hours after start-up	10 hours after start-up	5 hours after start-up	Start-up
Remove protective covers, shields, barriers if present									
Check coupling/shaft alignment and belt tension if present									
Tighten mounting bolts to pumps, driver, and other equipment									
Check seal gaskets/chamber oil									
Check seal gaskets/chamber oil									
Check bearing/gear housing oil									
Check bearing/gear housing oil									
Check bearing/gear housing oil									
Check bearing/gear housing oil									
Check bearing/gear housing oil									

Remove protective covers, shields, barriers if present
 Check coupling/shaft alignment and belt tension if present
 Tighten mounting bolts to pumps, driver, and other equipment
 Check seal gaskets/chamber oil
 Check seal gaskets/chamber oil
 Check bearing/gear housing oil
 Check bearing/gear housing oil
 Check bearing/gear housing oil
 Check bearing/gear housing oil
 Check bearing/gear housing oil

Make additional copies as necessary

The above forms will cover the initial inspection and intended storage and commission period for the pump, as well as the initial performance of the pump during commissioning. This information will be used to determine the effective warranty period of the pump/unit, and to verify that the pump meets the requested performance criteria. A copy of these forms will be sent with your LobePro pump, as well as a digital copy sent upon shipment.

The pump and order information will be pre-completed by LobePro, and the end user / operator will complete the remaining fields and conduct the inspection. The Recommended Service Log shall be completed during each inspection of the pump after commissioning. Refer to the Commissioning and Service Schedule for the recommended inspection and service interval, not to exceed two months between inspections or as otherwise recommended by LobePro.

To activate your warranty, complete and return both the LobePro Record of Receipt and the LobePro Installation and Commissioning Record. Upon receipt of your warranty forms, a LobePro representative will generate a Warranty Certificate (right) detailing your warranty period and conditions which may void your pump warranty.

In addition, we request that all warranty claims provide a record of regular service and inspection. For this purpose, this packet contains a Recommended Service Log. Users may also use their own inspection and service forms, as long as the same information is captured.

Please contact LobePro at info@lobepro.com for any questions regarding the installation, maintenance, or warranty of your pump.

Warranty Certificate

LOBEPRO ROTARY PUMPS WARRANTY

The document certifies that LobePro warrants this product to be free from defects in material and workmanship under normal operation and maintenance for a period of two years from the date of installation or 30 months from the date of shipment, whichever occurs first. The liability of LobePro under the warranty is limited to replacing, repairing, or issuing credit, at their option, for any parts or products WHICH ARE RETURNED BY PURCHASER during such periods, provided:

- The PURCHASER contacts the company directly for a Return Materials Authorization (RMA) number to return the product.
- LobePro is notified of the defect or product nonperformance prior to the expiration of the warranty term, as stated in this certificate.
- LobePro determines that defects exist and have not been caused by misuse, improper installation, alteration, or other interference.

In addition to the standard terms above, this warranty shall be considered void if the product is operated in a manner inconsistent with the provided application data and/or exceeds the following operating conditions:

- Incompressible solids greater than _____ inches (_____ mm)
- Operating speeds more than _____ rpm
- Differential pressure more than _____
- Operation without fluid (dry run) for more than _____
- Chemical attack or abrasion due to undisclosed chemical or material
- Failure to perform standard maintenance as outlined in the user manual

Other conditions not covered by this warranty include:

- Normal wear on any standard replaceable wear parts
- Defects or damage caused by the fault or negligence of the purchaser or third party
- Use of unauthorized repair parts or repairs completed by an unauthorized party
- Modifications made to the product by the purchaser or other unauthorized party
- Freight damage
- Freeze/Storage damage
- Damage resulting from misuse
- Additional warranty terms and conditions as agreed upon and included with this document.

End User / Operator: _____
 Job / Order No.: _____
 Pump Serial No.: _____
 Pump / Unit ID: _____

Warranty Start: _____ Warranty End: _____

Warranty Approved: _____
 Name: _____ Signature: _____ Date: _____

Pump Exchange Program and Remanufactured Pumps

In addition to our selection of new pumps, LobePro offers remanufactured pumps at a discounted price. Remanufactured pumps are available at a reduced price of 85% the cost of a new pump. Your pump will have all new wear parts, including mechanical seals, lobes, wear plates, and O-rings. All remanufactured pumps are warranted against defects in workmanship for 12 months after the date of shipment.

We also offer the ability to exchange your old pump for either a new or remanufactured LobePro pump. To qualify, your current pump must be in good working order and should only require the replacement of wear parts.

Pump Exchange Criteria:

All non-wear parts must be in good condition, including but not limited to the pump cover, quench chamber, flange ring, gear housing, shafts, bearings, and timing gears. If additional, minor repairs are needed, the discount amount may be reduced. If your pump does not meet this criteria, our team will contact you to explain and review other options.

When exchanging your current pump for a NEW LobePro pump:

1. Contact LobePro for a quote on a NEW LobePro pump and let them know that you plan to return your pump for an exchange evaluation. Depending on the nature of your application, you can arrange to send your pump to us at this time, or wait until you receive the new pump.
2. We will build and ship your NEW LobePro pump. If your current pump has not yet been returned and evaluated, you will be invoiced for the full cost of a new pump at this time.
3. After receiving your pump, please return your old pump to us for evaluation.
4. Upon receipt of the old pump, we will schedule an evaluation. If the condition of the frame and components (excluding wear parts) is satisfactory, then you will receive a credit of up to 15% toward your purchase. See Pump Exchange Criteria above.

When exchanging your current pump for a REMANUFACTURED pump:

1. Contact LobePro for a quote on a REMANUFACTURED LobePro pump and let them know that you plan to return your pump for an exchange evaluation. Depending on the nature of your application, you can arrange to send your pump to us at this time, or wait until you receive the new pump.
2. We will build and ship your REMANUFACTURED LobePro pump. If your current pump has not yet been returned and evaluated, you will be invoiced for 85% of the cost of a new pump at this time.
3. After receiving your pump, please return your old pump to us for evaluation.
4. Upon receipt of the old pump, we will schedule an evaluation. If the condition of the frame and components (excluding wear parts) is satisfactory, then you will receive a credit of up to 15% toward your purchase. See Pump Exchange Criteria above.

Benefits:

- **Limited downtime:** the current pump can continue operation until the new or remanufactured pump is delivered.
- **Extended warranty:** the new or remanufactured pump will come with its own warranty.
- **Reduced cost:** Save up to 15% of the pump cost for a new pump, or 30% of the pump cost for a new pump for a remanufactured pump.

1 USER SAFETY

To our valued customers,

User safety is the primary goal in the design, manufacture, and assembly of all LobePro rotary lobe pumps. Your attention to the instructions, notes, precautions, and warnings outlined in this manual will assist you in preventing the risk of personal injury and equipment damage.

Please ensure that you read and understand the contents of this manual prior to installing, operating, or performing maintenance on your rotary lobe pump. Observe all safety notes and warnings before start-up to avoid serious injury and/or equipment damage. Safety stickers are provided for quick reminders for safe operation and maintenance of this pump. Do not remove or cover these stickers at any time.

LobePro rotary pumps are designed to provide safe, reliable, and efficient service when installed, operated, and maintained properly, within the approved service conditions and operating parameters. This pump may be operated **ONLY** in accordance with the approved conditions, as described on the pump nameplate (Section 2.0) and in safety instructions provided in this document.

This LobePro Rotary Pump Installation and Maintenance Manual provides specific safety risks that every user should consider at all times. Thorough understanding of these precautions and warnings is required to ensure protection of personnel and equipment; however, observance of these warnings alone is not sufficient. It is the responsibility of the end user and all individuals involved in the installation, operation, and maintenance of this equipment to recognize and eliminate all unsafe practices.

LobePro, LLC is not responsible for injury, death, or other losses resulting from a failure to observe these safety warnings and precautions or any misuse or abuse of the rotary lobe pumps, drive equipment, or auxiliaries.

LobePro Rotary Pumps
2610 Sidney Lanier Drive
Brunswick, GA 31525
Phone: 912-466-0304
Fax: 912-466-0086
info@lobepro.com
www.lobepro.com

1.1 Safety Terminology and Symbols

Observe all safety notes, precautions, and warnings highlighted in this Installation and Maintenance Manual



Electrical Hazard:

Indicates the possibility of electrical risks or danger if directions are not followed or which may result from unsafe practices which could result in severe injury or death.



Caution/Warning:

Indicates a hazardous situation or unsafe practice which could result in injury or damage to equipment or personnel.



Important Note:

Indicates important information that pertains to a specific topic, procedure, or subject. Users should be aware of this information when performing the task.



Explosive Atmosphere or Environment:

Indicates that the following instructions must be followed when the pump is installed in potentially explosive atmospheres. Contact LobePro for any questions regarding these requirements.

1.2 Important Safety Instructions and Warnings

LobePro will not accept responsibility for physical injury, equipment damage, or delays caused by failure to observe and follow the instructions contained within this manual.



Never operate this positive displacement rotary lobe pump with the suction/intake or discharge/outlet ports blocked or closed. Ensure that these ports are cleared at all times unless the pump is properly locked out and prevented from operating. Operation of the pump with blocked ports can cause over pressurization or overheating, which may result in a violent explosion. Necessary measures must be taken by the owner/operator to prevent these conditions.



This positive displacement pump may handle hazardous or toxic fluids which may be harmful to individuals or the environment. The end user **must** identify the contents of the pumped fluid to avoid the possibility of exposure. Potential hazards may include, but are not limited to: high pressure, high temperature, flammability, acidity, causticity, explosivity, high noise, or other risks.



This manual clearly identifies accepted methods for assembly and disassembly of the LobePro positive displacement pump. **DO NOT** use heat to remove lobes, shafts, or other retaining parts unless otherwise directed by LobePro personnel. Residual liquids inside the pump can rapidly expand and may result in personal injury, death, or damage to the equipment and surrounding area.

1.2.1 General Safety Instructions

Read before installing, operating, or performing maintenance on this pump.

- Do not wear loose clothing which may become entangled in rotating or moving parts.
- When working on this pump, always wear approved personal protective equipment (PPE) or safety gear, such as safety glasses, compatible gloves and clothing, and other necessary equipment for the service location.
- Do not substitute pump parts and fittings with other materials without prior approval from LobePro personnel. Contact LobePro for material compatibility recommendations.

1.2.2 Pump Safety Instructions

Installation

- Do not exceed the LobePro allowable forces and moments on the pump fittings or nozzles. This may cause unwanted load or strain on the pump, resulting in misalignment, excessive vibration, or the formation of leaks. Pipe stress may adversely affect the operation of the pump, resulting in premature damage to or failure of the pump, drive equipment, or auxiliaries. Contact LobePro for allowable loading.
- Do not block or restrict the intake or outlet ports. Flexible hoses may whip under pressure, causing injury or equipment damage.

Start-up

- This pump requires wet priming when first started or returned to service following maintenance.
- Do not operate the pump until all personnel are clear.
- Do not operate this pump without its inlet and outlet ports connected such that unsafe access to the pumping chamber is possible.
- Do not operate the pump without the cover/door or driveshaft guards installed.

Operation

- Do not exceed the operating parameters shown on the pump nameplate (Section 2.0) unless otherwise approved by LobePro personnel.
- Do not operate this pump without guards and safety devices in place. The following safety devices may be used to protect against dangerous operating conditions:
 - Current limiter on the motor
 - Pressure relief valve
 - Cut-off pressure switch
 - Temperature monitor
 - Flow rate gauge
- Do not pump hazardous materials without prior approval by LobePro; the pump shall only be used as originally approved by LobePro.
- When pumping high viscosity mediums, the pump speed must be reduced accordingly to prevent cavitation.
- Operation against a closed discharge/outlet valve may cause premature bearing and seal failure. Operation with a closed intake valve may cause the generation of excessive heat. It is recommended that the pump be operated with a high temperature switch and pressure relief valve to avoid dangerous conditions.
- Do not exceed manufacturer recommendation for maximum performance, as this may cause the motor to overheat.

Maintenance

- Do not start or attempt maintenance procedures while the pump is in motion.
- Before any maintenance is performed, the electrical power source to the driver must be isolated and locked out to ensure that power is not restored until it is safe.
- Pumps generate heat and pressure during operation; allow time for the pump to cool before handling or performing any maintenance.
- Only qualified or properly-trained personnel should install, operate, and/or perform maintenance on this pump. Training is provided by LobePro, at our factory, on a semi-annual basis, or as otherwise arranged on an individual basis.

- Do not clean the pump or piping system with fluids that may be incompatible with pump materials, or under conditions such as high temperature or pressure which may cause damage to the pump. Contact LobePro for recommended cleaning practices.
- Do not use the gearbox, motor, or pump lifting eye bolts to handle or lift the equipment baseplate/skid. Use only lifting handles and other devices expressly provided for movement of the baseplate.
- Equipment eye bolts, such as those for the pump, motor, or other equipment, are to be used for movement of ONLY that equipment.
- Relieve all internal pressure before beginning any maintenance work.

1.2.3 Electrical Drive Safety Instructions

- Always ensure that the pump is electrically isolated or disconnected from the power supply before attempting any maintenance. Lock out the driver power supply to prevent electric shock, accidental start-up, and personal injury.
- To reduce the risk of electric shock, the motor and all electric auxiliaries shall be properly grounded in accordance with the National Electrical Code (NDE) or Canadian Electrical Code and all applicable state, province, local, and standard international codes.
- All wiring and termination of electrical wires/cables shall be performed by qualified or trained personnel.
- Use only wires which are rated and recommended by the motor manufacturer. Do not operate the pump with a power code which is frayed or has brittle insulation.
- Wiring shall be protected at all times to avoid punctures, cuts, or other damage, and shall be inspected frequently.
- Never operate a pump with a power cord without a ground fault circuit interrupter.
- Never handle power cords or other electrical equipment with wet hands or clothing.

1.2.4 Gas/Diesel Engine Pump Drives

- Never operate gas/diesel engines:
 - In an enclosed building or area where exhaust gases may accumulate.
 - Near a building where exhaust gases can seep inside.
 - In a pit or sump without appropriate provisions for adequate ventilation.
- Do not breathe exhausted fumes when working in the area of the engine; exhaust fumes are an odorless, deadly poison.
- The engine may be noisy during operation; use appropriate ear plugs to minimize noise and hearing loss/damage.
- Allow the exhaust system to cool before touching.
- Never add fuel to the tank while the engine is running.
- Do not smoke or handle any open flame while refueling the engine.
- Carefully read all instruction manuals supplied by the engine manufacturer before attempting to assemble, operate, or serve the engine in any way. The warnings, cautions, and notes provided indicate potential hazardous conditions for the operator or equipment.

1.2.5 Hydraulic Pump Drives

- Avoid hazard by relieving pressure before disconnecting hydraulic lines; escaping fluid under pressure may penetrate the skin causing serious injury.
- Never use your hand or any other body part to check for leaks in a pressurized line.
- Tighten all connections before applying pressure and inspect hoses regularly for wear or damage.
- If an accident occurs, see a doctor immediately. Any fluid injected into the skin may need to be removed within a few hours to avoid gangrene.

1.2.6 Explosion Proof Environments

- Never operate the pump without heat or temperature shutoff switches or protection.
- Always lock out all power supplies to the pump and driver before attempting to perform any maintenance work.
- Do not operate the pump with the suction/intake valve(s) closed; this may lead to dangerous temperature conditions caused by dry operation.
- Do not operate the pump with the discharge/outlet valve(s) closed; this is a positive displacement pump and will continue to generate pressure when operated against a closed valve.
- Always follow the coupling recommended installation and operation procedures.
- Never exceed the operating parameters shown on the pump's nameplate (Section 2.0).
- Do not exceed the LobePro allowable forces and moments on the pump fittings or nozzles. This may cause dangerous strain on the pump, resulting in misalignment, excessive vibration, or the formation of leaks. Pipe stress may adversely affect the operation of the pump, resulting in premature damage to or failure of the pump, drive equipment, or auxiliaries. Contact LobePro for allowable loading.
- Only use motors/drives which are certified with explosion proof classification.
- All pump directional flow valves, controls, and instrumentation shall be properly positioned and set if reversible operation is desired.

ATEX Explosion Proof Environment Use



When operating LobePro rotary pumps in potentially explosive atmospheres, LobePro recommends that special care is taken into consideration for the operation and maintenance of these pumps. Proper care includes, but is not limited to:

- Monitoring of fluid temperature and process conditions
- Oil temperature and pressure monitoring for the pump frame, seal quench chamber, and gear housing
- Level monitoring for the seal quench chamber and gear housing
- Verification that the pump is operating within the rated conditions for flow, speed, temperature, and pressure.

Installing, operating, and maintaining the pump and or pump skid/unit in any manner not covered in this Installation and Maintenance Manual may cause damage to the pump or unit as well as serious injury to personnel. ATEX conformance is only applicable when the pump or unit is installed, operated, and maintained within its rated conditions and intended use.

Please contact engineering@lobepro.com with any questions or comments before operating these positive displacement pumps in a potentially explosive environment.

When handling hazardous fluids, it is important to take care to avoid exposure to the fluid through appropriate storage and maintenance of the pump, operator training, and limited personnel access. For flammable or explosive fluids, strict safety measures must be applied.

These procedures ensure that the pump is in compliance with the European Directive 94/9/EC, known as the ATEX Directive, which is mandatory in Europe and may be specified for other locations. These measures shall also be followed for regions in which ATEX is not the applicable regulation, to ensure safe operation. These measures are further described in Sections 1.3 to 1.5.

1.3 Scope of Compliance

This LobePro rotary pump shall only be used in the zone for which it is appropriate. Always ensure that driver, driver coupling, seal, and pump equipment are suitably rated and/or certified for the zone and classification of the specific atmosphere of the installation site. Where LobePro has provided only the pump, the Ex rating applies only to the pump. The party providing the baseplate, driver, and other equipment shall be responsible for selecting the necessary CE Declaration of Conformity, establishing that it is suitable for the intended installation area.

The output from a variable frequency drive (VFD)/variable speed drive (VSD) may cause additional heating effects in the motor. For equipment operated with a VFD, the ATEX certification for the motor must state that it covers such operation. This requirement shall apply even if the VFD is in a safe area.

Temperature classification, Tx, is used when the liquid temperature varies and the pump could be installed in different hazardous atmospheres. In this case, the user is responsible for ensuring that the pump surface temperature does not exceed the permitted temperature for that atmosphere. The maximum allowable operating temperature can be found on the LobePro rotary pump nameplate (Section 2.0).

If an explosive atmosphere exists at the time of installation, DO NOT attempt to check the direction of rotation by starting the pump dry (without fluid). Even a short run time may result in high temperatures generated by the contact between rotating and stationary components. Confinement of fluid in the pump and piping must be avoided; the generation of heat may cause excessive pressure or head, resulting in the bursting of components. Always ensure that all valves are open to the pump before operating.

When there is any risk of the pump operating against a closed valve, it is recommended that users fit an external temperature protection device. Avoid mechanical, hydraulic, or electrical overload by using motor overload trips, temperature monitors, or a power monitor, and monitor vibration routinely.

In dirty or dusty environments, regular monitoring should be in place to ensure that dirt is removed from areas with close clearances, bearing covers, and motors.

1.4 Preventing Build-up of Explosive Mixtures in the Pump



Ensure the pump is properly filled and vented when pumping hazardous fluids.

Ensure that the pump and relevant suction and discharge piping is completely filled with fluid at all times during pump operation. Also ensure that the seal quench chamber and gear housing oil levels are properly filled to the recommended level (visible in the oil level sight glass). If the operation of the pump cannot avoid the above conditions, the fitting of an appropriate protection device shall be recommended, such as fluid detection, flow, or no-flow sensors.

1.5 Preventing Sparks

To prevent a potential hazard resulting from contact of mechanical, rotating components, the coupling guard shall be made of a non-sparking material. Correct alignment of the coupling and driver shall be maintained. Where applicable, the coupling shall be selected to comply with 94/9/EC.

To avoid potential electrical hazards, the motor and baseplate shall be properly grounded.

To avoid electrostatic discharge, do not rub non-metallic surfaces with a dry cloth; use only a clean cloth appropriately wetted.

When metallic components are fitted on a non-metallic baseplate, the pump MUST be independently grounded.

1.6 Preventing Leakages

LobePro rotary lobe pumps are sold on an application-specific basis, accounting for fluid compatibility, operating speed, pressure, and other application parameters. The pump should only be used to handle fluids as reviewed and approved by LobePro at the time of purchase. If intending to use the pump in a separate application, contact engineering@lobepro.com to verify fluid compatibility and review the recommended operation.

Avoid closing the suction and discharge valves to the pump, entrapping fluid within the pump and piping. Excessive heat may result in dangerous pressures, even when stationary. Freezing of the contained fluid may also result in damage to the pump and/or personnel injury. Refer to Section 4.3.3 for instructions on storing the pump during cold weather/low temperature conditions.

The pump and fluid must be closely monitored when there is risk of a loss of seal buffer fluid or external flushing.

If a leakage may result in an environmental hazard, the pump should be installed with a liquid detection device.

1.7 Maintenance to Avoid Hazards



Correct maintenance is required to avoid potential hazards which may result in equipment damage or personnel injury. It is the responsibility of the plant/equipment operator to ensure compliance with recommended installation, maintenance, and storage procedures.

To avoid potential hazards during maintenance, the tools, cleaning, and painting materials should not give rise to sparking, or adversely affect ambient conditions. Where such a risk exists, maintenance shall be conducted in a safe location. It is recommended that a maintenance plan is enacted to ensure the pump performs as expected.

1.8 Environmental Safety



Always keep the work area and operating site clean to avoid and/or discover any leakages or emissions.

Recycling

- Follow all laws and regulations regarding recycling and the disposal of parts
- Contact LobePro about recycling used lobes

Waste and Emissions Regulations

- Handle and dispose of all process fluid in accordance with applicable environmental regulations
- Clean-up all spills in accordance with safety and environmental procedures
- Report all environmental emissions to appropriate authorities

1.9 User Safety

1.9.1 General Safety Rules

- Ensure that all safety devices and control systems are functioning properly
- Always keep the work area clean and free from clutter and loose items
- Pay attention to risks presented by gas or vapors in the work area
- Avoid electrical dangers; pay attention to the risks of electric shock or arc flash hazards
- Be aware of the risk of drowning, electrical accidents, and burn injuries

1.9.2 Safety Equipment

Required personal protective equipment (PPE)/safety gear shall be determined by the plant/site operator, and may include:

- Hard hat / helmet
- Safety goggles, especially with side shields
- Protective / steel-toe shoes
- Compatible, protective gloves
- Hearing protection
- Gas mask
- Flame resistance clothing
- First aid kit

1.9.3 Personnel Training

Only individuals thoroughly trained and instructed should perform work on the pumps. The operator must clearly define the responsibilities of each person operating, servicing, and maintaining the equipment. A person to be trained may only perform work on the pump under the direct supervision of a trained individual. It is important to ensure that individuals are properly trained in operating and maintaining

LobePro provides training semi-annually at its facility in Brunswick, GA. Training may also be arranged on a special basis at the customer's facility or on-site as needed.

LobePro and its distributors can also be hired for pump repairs, either on-site or by sending the pump for servicing.

2 LOBEPRO PUMP IDENTIFICATION

In order to provide service and information on our pumps once they have left the factory, LobePro makes use of unique tracking numbers and tags for each pump and assembly.

- Serial number: Unique identification number; preferred tracking reference
- Baseplate ID: Contains reference to pump frame, driver, and LobePro order number. Each baseplate ID is tied to a unique pump serial number.
- Model: Non-unique identifier of pump materials of construction

2.1 LobePro Pump Serial Nameplate

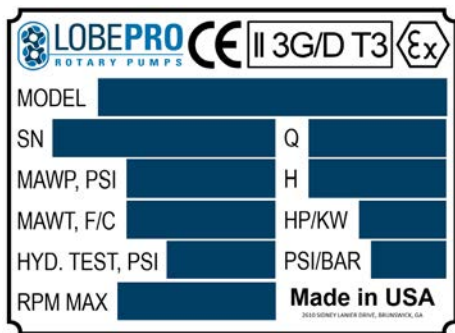

Shown to the left is the standard pump serial nameplate, located on the pump gear housing. The CE and Ex markings designate the ATEX compliance with the following designations: (Example Only)

- II: Zone for combustible gases, vapors, mists
- 3: Category 3
- G/D: Explosive gas and dust are present
- T3: Temperature class (200 °C / 392 °F)

Note: Please refer to ATEX Directive/CE Marking for additional equipment group, category, and temperature classes:

- Model: LobePro pump series, frame size, shaft configuration, and materials (Section 2.2)
- SN: Unique serial number
- MAWP: Maximum allowable working pressure (psi)
- MAWT: Maximum allowable working temperature (°F/°C)
- HYD. TEST: Hydrostatic test pressure (psi), if provided
- RPM MAX: Maximum allowable operating speed, application-specific
- Q: Rated flow rate (gpm, lpm, m3/hr, etc.)
- H: Total dynamic head (feet/meter)
- HP/KW: Recommended/provided motor/driver power
- PSI/BAR: Maximum process application differential pressure



The code classification marked on the pump, driver, and other equipment provided must be in accordance with the specified area where the pump, driver, and equipment will be installed.

It is the responsibility of the customer to provide the details of the explosive environment where the pump and equipment will be installed and operated. Contact LobePro for any questions related to explosion proof classifications.

2.2 LobePro Pump Model

SM50.T-AGCGVGQAMS-NEFAN4h-123456

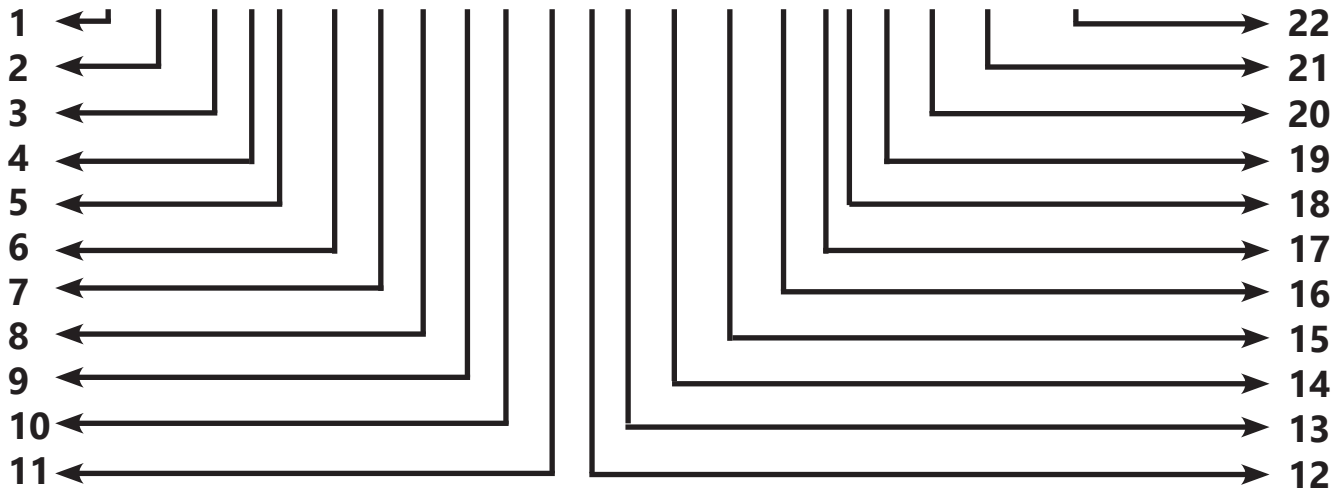

1 - Certification / Service:

S - General Use, Sludge, Mud & Slurries
 C - Chemical & Corrosive
 D - Duplex Steel-Oil & Gas
 API - API 676 Compliant (Available in each Service)

2 - Pump Frame:

S - Small
 M - Medium
 L - Large

3 - Rate Capacity/Size:

Gallons per 100 revolutions

4 - Shaft Support or Arrangement:

. - Overhanging shafts
 h - Fully supported shafts
 p - Proform pump casing
 c - Component/adjustable housings

5- Driver Shaft Configuration:

T - Top Drive
 B - Bottom Drive
 H - Top Hydraulic

6 - Shaft Material:

-A - A4140 Steel
 -S - 440A Stainless Steel
 -X - Custom

7 - Pump Cover:

G - Grey Iron
 C - Carbon Steel
 S - 316 Stainless Steel
 T - Grey Iron - CIT coated
 D - Duplex 2205
 H - Grey Iron HP Door
 U - Grey Iron - CIT coated HP Door

8 - Flange Ring:

C - Carbon Steel
 S - 316 Stainless Steel
 D - Duplex 2205
 _ - None

9 - Housing Segment / Casing:

A - AGI-600 Grey Iron
 D - CD3mn Duplex Steel
 S - 316 Stainless Steel
 G - Class 30 Grey Iron
 C - Carbon Steel

10 - Housing Segment Gasket

V - Vegetable Fiber
 K - C7400 Aramid Fiber
 E - EDPM
 F - FKM

11 - Seal Quench Chamber:

G - Grey Iron
 T - Grey Iron - CIT coated
 C - Carbon Steel
 S - 316 Stainless Steel

12 - Oil Drain Connections:

D - Standard Plugs
 Q - Brass/Steel Quick Drain Hoses
 S - Stainless Steel Quick Drain Hoses

13 - Transition Fittings:

A - Standard Steel Transition Fitting
 S - Standard SS Transition Fitting
 X - Special Transition Fitting
 _ - No Transition Fitting

14 - Transition Fitting Gaskets:

M - Multi-Swell
 F - FKM
 E - EDPM

15 - Pressure Disc:

S - 316 Stainless Steel
 D - Duplex Stainless Steel
 L - High Pressure Door SpaLh.SS

16 - Mechanical Seal Assembly:

N - LARS.D.EN.F
 S - LARS.SC.SS.F
 V - LARS.TC.DS.F
 See next page for full description.

17 - Strain Bolts:

E - Geomet-coated Steel
 S - 316 Stainless Steel
 D - Duplex Stainless Steel
 N - HP Door Lh Steel Nut

18 - Orings:

F - FKM
 N - NBR
 H - HNBR
 E - EPDM

19 - Wear Plates:

A - AR500
 S - 316 Stainless Steel
 D - Duplex 2205

20 - Lobe Coating / Core Material

N - NBR Steel Core
 G - NBR GI Core
 H - HNBR
 E - EDPM
 F - FKM

21 - Lobe Shape:

4h - 4 Wing Helix
 6h - 6 Wing Helix
 6s - 6 Wing Straight
 2s - 2 Wing Straight

22 - Serial Number

Common/standard material options presented only; other material options available upon request, or as necessary for the application. Contact LobePro for further details.

Mechanical Seal Assemblies

Mechanical seal assemblies are comprised of three customizable components, the seal face material, seal carrier material, and O-ring material, and are named in the format of:

LARS.X.Y.Z

X Seal face material

D – Duronit (S-series standard)
 SC – Silicon carbide (C- and D-series standard)
 TC – Tungsten carbide

Y Seal carrier material

EN – Electroless nickel-plated carbon steel
 SS – 316 stainless steel
 DS – 2205 duplex stainless steel

Z O-ring material

E – EPDM
 F – FKM (standard)
 X – Custom

The seal assemblies are then presented in the Pump ID/CATHOWLS as:

6 Mechanical Seal Assembly

N – LARS.D.EN.F
 U – LARS.TC.EN.F
 S – LARS.SC.SS.F
 Q – LARS.TC.SS.F
 E – LARS.SC.DS.F
 V – LARS.TC.DS.F

Common seal configurations are presented above; other seal material combinations are available upon request, or as necessary for the application. Other seal O-ring materials are available, but may increase the total lead time for a new pump or seal assembly.

2.3 Baseplate ID

In addition to the pump serial nameplate, LobePro packaged units also include a baseplate ID, welded or otherwise secured to the bent or structural baseplate.

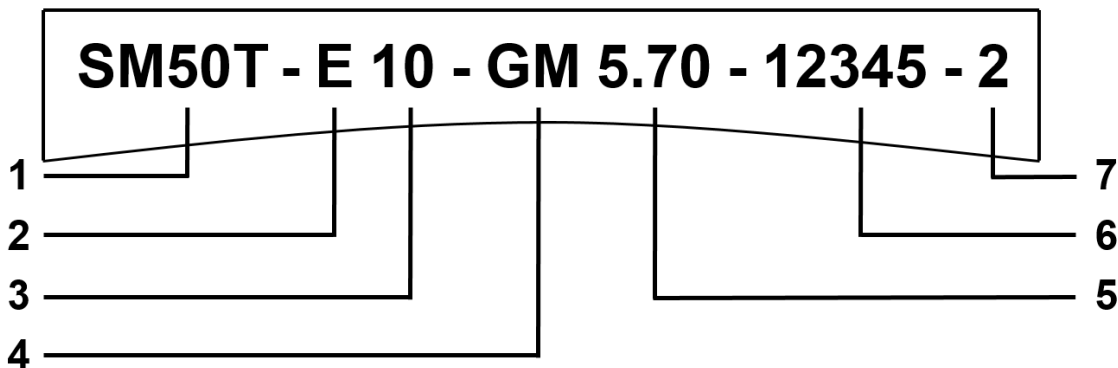

1 Pump Description (Section 2.2)

2 Pump Driver

E – Electric induction motor

3 Driver Power (HP)

4 Gear Reduction

GM – Gear reducer
 PB – Belt drive

5 Gear/Belt Reduction Ratio (ex. 5.70:1)

6 LobePro Order Reference No.

7 Unit No. (if multiple in order)

3 LOBEPRO PUMP BASICS AND OPERATION

3.1 General Pump Description

LobePro rotary lobe pumps are positive displacement type pumps, with non-contacting rotors/lobes. The standard helical lobe is designed to provide smooth, pulsation-free, dependable pumping with easy handling and "maintenance in place" capabilities. Rotary lobe pumps are best suited to transfer fluids in any system involving the following conditions:

- High solids concentrations
- High viscosity
- Entrained gases
- Abrasives
- Sensitivity to shear stress

As a positive displacement pump, LobePro pumps provide a continuous, relatively constant flow rate for any given differential pressure. Rotary lobe pumps may be operated intermittently, or on a continuous/constant basis. They offer full reversibility and may be operated dry (without fluid) for brief periods of time. When initially wetted, LobePro pumps can self-prime up to 25 ft (7.6 meters), depending on fluid properties, suction conditions, and overall piping design.

3.1.1 Typical Uses and Applications

Rotary lobe pumps are used in a wide range of applications and industries, including:

- Water
- Wastewater
- Pulp and paper
- Food & dairy
- Beverage
- Pharmaceutical
- Oil and gas
- Power and Energy
- Bio-fuel
- Mining
- Sugar processing
- General dewatering

3.1.2 Solids and Viscosity Handling

Rotary lobe pumps can handle relatively soft/compressible solids, as well as medium hard solids, without damaging the pumped product. The maximum allowable size (diameter) of the solids varies in accordance with pump frame/size as follows:

Pump Models	Maximum Compressible (Soft) Solid Size	Maximum Incompressible (Hard) Solid Size
S8c, S8p, S16c, S16p	3/4 in. (19 mm)	1/8 in. (3 mm)
M34, M50, M68, M100	1-1/2 in. (38 mm)	1/8 in. (3 mm)
L133, L266, L399, L531*	2-1.2 in. (50 mm)	1/8 in. (3 mm)

* Includes high pressure frame variants

Refer to Section 3.5.1 for more information on solids handling and advisories.

Careful selection of the pump frame/size, materials of construction, operating speed, flow rate, dynamic head, power consumption, and other system requirements shall be considered before specifying a pump for use.



LobePro rotary pumps are recommended for use with viscous products, but the increased resistance to flow requires that the rated operating speed be reduced to achieve satisfactory performance.

3.1.3 Operation and Performance

The overall performance and efficiency of a rotary lobe pump depends greatly on the proper selection of the pump, its rating, and its materials of construction. Improperly selected materials of construction may result in premature failure due to material incompatibility. For this reason, it is imperative that all application and fluid details are provided when selecting a pump. Similarly, pumps which are under-sized, or intended to run close to their maximum allowable operating speed, may wear prematurely, requiring excessive replacement part expenses and downtime due to maintenance.

3.2 Direction of Rotation and Flow

Rotary lobe pumps consist of one or more pairs of intermeshing lobes. The opposing rotation of the lobes creates an expanding cavity on the suction (intake) side of the pump. The process fluid flows into this cavity and is trapped between the lobe tips and casing as the lobe rotates toward the discharge (outlet) side of the pump. The fluid does not travel between the lobes. As the lobe tips mesh again, the fluid is pushed out of the discharge side of the pump.

The lobes do not contact each other due to the orientation of shafts, set by the timing of gears. This timing is completed during initial assembly and does not require adjustment or correction when the pump is operated and maintained in accordance with the instructions provided in this manual.

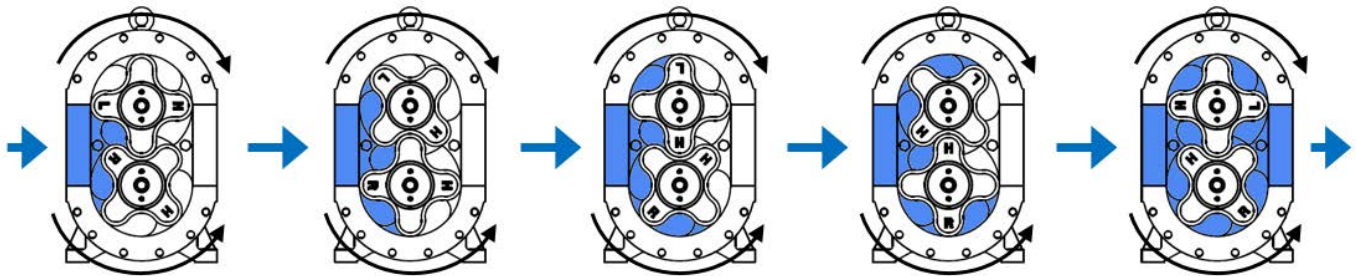

Fig. 3.2.1 "Forward" flow direction (arbitrary)

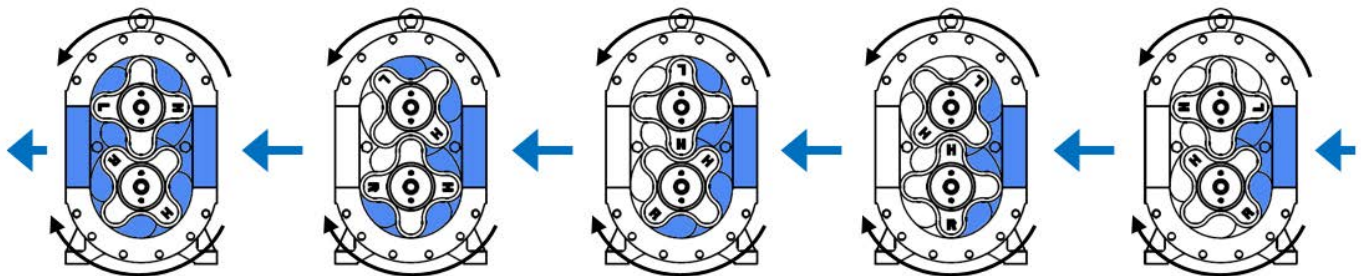

Fig. 3.2.2 "Reverse" flow direction (arbitrary)

The helical profile of the lobe creates pulsation-free performance when operated within LobePro recommended speed ranges and in accordance with the differential pressure and fluid properties. Pump shafts are supported by bearings located in the gear housing and seal quench chamber. The position of these bearings determines shaft deflection, which is used to determine the maximum allowable differential pressure without contact between the lobes.

3.3 Direction of Flow and Drive Configuration

In Section 3.2, it is shown that the flow direction depends on the direction of rotation for each lobe. This rotation is based upon the drive shaft location; whether it is located in the top or bottom position for the pump.

As shown in Fig. 3.2.1 and 3.2.2, the two shafts rotate in opposite directions. As such, a "top drive" assembly will rotate opposite a "bottom drive" assembly for the same flow direction. This is shown in Fig. 3.3.1 and 3.3.2 for the "forward" flow direction shown in Fig. 3.2.1.

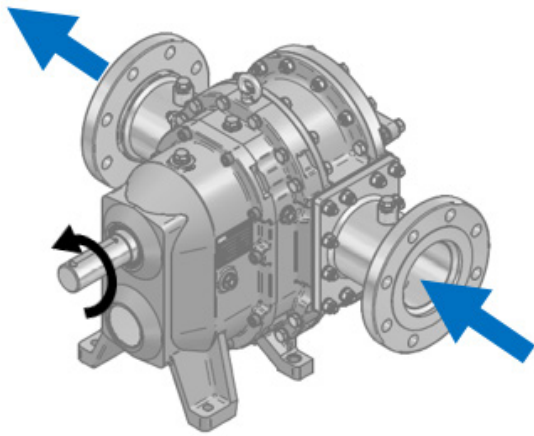

"Top Drive" Configuration
Fig. 3.3.1 Shaft rotation for "forward" flow direction as shown in Fig. 3.2.1.

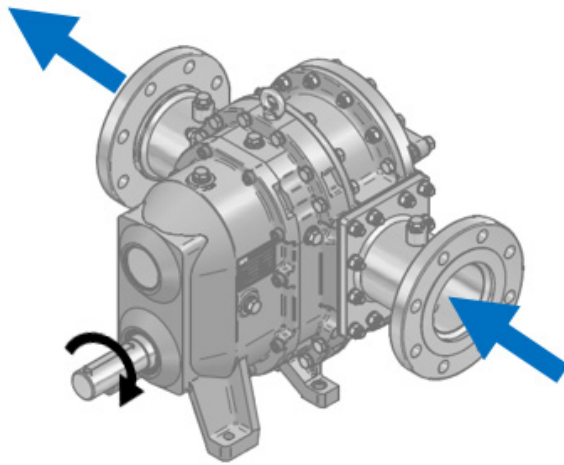

"Bottom Drive" Configuration

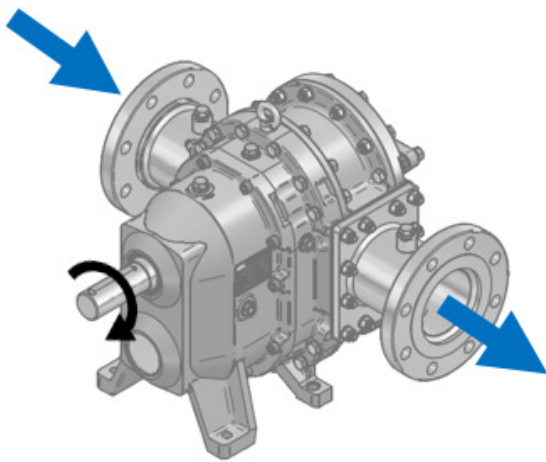

"Top Drive" Configuration
Fig. 3.3.2 Shaft rotation for "reverse" flow direction as shown in Fig. 3.2.2.

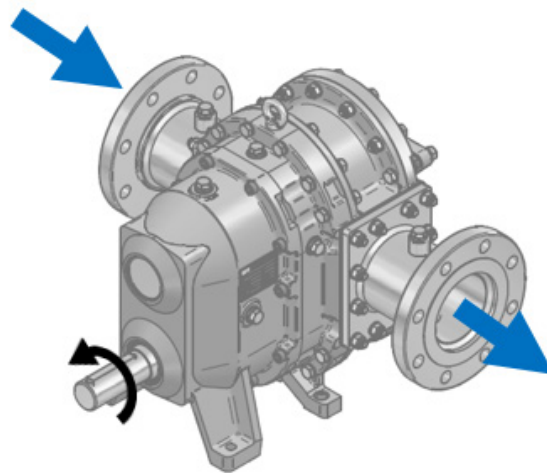

"Bottom Drive" Configuration

3.4 Start-up and Priming

For new installations, or when a pump is returned to service after maintenance or other down time, rotary pumps should be wet primed upon first use. As noted in the commissioning instructions, wet priming involves ensuring that the pump casing and fittings are filled with an initial fluid level.

After the lobes have worn-in, pumps may dry prime for a limited period of time, and only for applications with minimal lift requirements. Applications involving greater lift, higher viscosities, or low speeds may require wet priming at all times.

Pump speed may be increased upon initial start-up to facilitate priming in suction lift applications, and later reduced when the pump has primed successfully.

For applications with positive (flooded) suction pressure, opening the valves to the suction/intake port of the pump should be sufficient for immediate priming of the pump.

3.5 Process Advisories

3.5.1 Solids Handling

LobePro pumps are capable of accommodating compressible, spherical solids of limited size, as shown below:

Table 3.5.1 Maximum Allowable Solid Size (Spherical)

Pump Models	Maximum Compressible (Soft) Solid Size	Maximum Incompressible (Hard) Solid Size
S8c, S8p, S16c, S16p	3/4 in. (19 mm)	1/8 in. (3 mm)
M34, M50, M68, M100	1-1/2 in. (38 mm)	1/8 in. (3 mm)
L133, L266, L399, L531*	2-1.2 in. (50 mm)	1/8 in. (3 mm)

* Includes high pressure frame variants

Rocks, wood, high concentrations of sand, incompressible solids, etc. larger than these sizes above may cause excessive wear of the lobes and housing segments, reducing pump efficiency or even causing failure. LobePro recommends that all systems include a reliable filtering system to keep these unwanted solids away from the pump.

Compressible (Soft) Solids

Compressible solids are solids that can be compressed, reduced, or otherwise changed in size. LobePro rotary pumps can accommodate these solids in accordance with Table 3.5.1. Due to the rotating motion of the lobes, these solids may generate excessive noise or vibration when moving through the pump, depending on the nature of the solid. Please consult LobePro for proper pump selection to accommodate solids in the process fluid.

Incompressible Solids

Incompressible solids are rigid and unchanging, and can potentially damage the lobes and seals, create a blockage in the piping system, damage instrumentation, or otherwise cause undesirable damage to the pump and piping system. LobePro recommends that all systems include a reliable filtering system to keep these unwanted solids away from the pump.

Incompressible solids exceeding 1/8 in. (3 mm) in size can be handled on an intermittent basis, but will increase the risk of damage/excessive wear of the rubber lobes and eventual lobe failure. Contact LobePro if the pump will be handling such large solids on a regular basis.

3.5.2 Thick/Viscous Fluid Handling

Rotary lobe pumps are often used to handle thick, viscous fluids which cannot be moved with or may cause damage to centrifugal pumps. When using the pump for viscous sludges, slurries, or other fluids, the pump speed must be reduced in accordance with the fluid viscosity in order to prevent cavitation or pockets of air which may damage the lobes. The allowable operating temperature and pressure range may also vary with fluid viscosity. Contact LobePro to verify recommended operating parameters before using these pumps in such applications.

3.5.3 Other Process Slurries and Multi-phase Process Fluids

LobePro recommends that the pump be flushed and cleaned, preferably with water, after each use and prior to shutdown for all processes in which the process fluid:

- May stiffen, solidify, or otherwise change phase or composition when stationary
- Contains suspended solids which may settle and harden

Refer to Section 3.5.5 for recommendations for operation in low temperatures and Section 4.3.3 for storage requirements in such conditions.

3.5.4 Wellpoint Applications

LobePro pumps are well-equipped to handle air-water mixtures in wellpoint applications. Ensure that the suction line is airtight to avoid losing vacuum pressure and reducing lift capabilities. Loss of vacuum pressure may cause the pump to operate dry, or with minimum fluid, causing the pump to overheat. LobePro recommends that pumps in wellpoint applications are fitted with low vacuum and high temperature monitors.

3.5.5 Operation in Adverse Temperature Conditions

Operating in Winter/Freezing Conditions

When there exists a risk of frost or freezing of the fluid in either the pump or piping system, the pump must be shut down and drained until all fluid has been removed from the pump. To fully drain the pump, the pump cover must be removed to drain fluid trapped between the lobes and the casing. It is also recommended that the casing be flushed or rinsed to remove entrained solids. Refer to Section 4.3.3 for cold weather storage requirements. Before start-up, re-fill the casing with fluid to facilitate priming, as noted in Section 3.4. Observe all safety notes and warnings before start-up to avoid serious injury and/or equipment damage.

Pump and Piping systems and components shall be properly heat traced to maintain the desired operating temperature of the process fluid



To avoid difficulty starting or operating the pump in adverse weather, ensure that a compatible oil is used in the seal quench chamber and gear housing. Refer to Section 8 for lubrication recommendations.

Operating in Hot & Humid Conditions

During hot weather, the fluid may vaporize inside the pump or piping. Vapor formation inside the system may increase pressure and cause undue damage to the pump and system. It is recommended to use valves and ventilation taps in the system to accommodate vapor formation.



Ensure that all valves, ventilation systems, and other controls are operational and reliable before operating the pump. Observe all safety notes and warnings before start-up to avoid serious injury and/or equipment damage.

3.6 Recommended Controls

Regular inspection and preventative maintenance are key to extending the life of your pump. In order to facilitate this, LobePro recommends the use of monitoring systems, switches, and controls to protect the pump and system during operation. These monitoring systems and controls may include the following:

Flow control/monitoring:

- Low pressure switch
 - A decrease in pressure may indicate excessive wear in the pump, or failure of the lobe which has reduced pump efficiency.
 - A lack of pressure generation may indicate that there is no fluid in the pump, or that wear or failure has compromised the pump's ability to move the fluid (and generate pressure).
- Flow meter/fluid detection system
 - For applications with strict flow rate requirements, flow monitoring and feedback to a control system will be required to determine appropriate speed adjustments to increase or reduce flow accordingly.

Pressure control/monitoring:

- Pressure relieving valve
 - To protect the pump from over pressurization that may cause the eventual failure of the pump mechanical seal or other components.

- Pressure regulating valve/device
 - This valve/device has the same intent as the pressure relieving valve.
- High pressure switch
 - This pressure switch has the same intent as the pressure relieving valve.

Temperature control/monitoring:

- Low temperature switch
 - Applications with viscous fluids often require a set temperature range to ensure the fluid can flow. A low temperature switch can shut down the pump when temperatures fall below this to ensure the pump is not operating under adverse conditions.
- High temperature switch
 - As with the low pressure, high temperatures in the pump casing may indicate that there is no fluid in the pump, or other upset conditions in the process.

Other controls/monitoring:

- Vibration monitoring:
 - Excessive vibration can result from a number of conditions, including cavitation, component failure, or the presence of large/excessive solids. Preventing the pump from operating for prolonged periods under these conditions is key to ensuring longevity of the pump.
- Oil moisture/contamination sensors:
 - Contamination of the gear and bearing chamber (gear housing) can lead to bearing failure, often requiring a complete rebuild of the pump. Detecting this contamination early by monitoring the oil of the seal quench chamber can allow you to replace seals or correct the operating conditions early and save significant repair costs. Determining the most effective device for your application depends on a thorough understanding of the fluid and its interaction with the lubricating oil.

4 SHIPPING, HANDLING, AND STORAGE

4.1 Packaging and Shipping

Following assembly and testing, all entrapped water is drained from the pump casing and all surfaces shall be cleaned and dried prior to crating.

Pump nozzles and flange faces shall be protected by a plastic guard with more thorough protection available upon request. Nozzles and other major components shall not be dismantled for shipment or installation unless written permission is received from the factory.

All exposed finished surfaces shall be protected from rust and corrosion, including the application of a rust primer spray or temporary lubricant, such as LPS 2®.

All bareshaft pumps are securely mounted to a rigid crate using the four (4) to six (6) mounting holes of the pump frame. Depending on pump size and order quantity, crates may be built to store multiple pumps. Packaged units shall be similarly mounted using a minimum of four (4) mounting holes in the baseplate or unit frame. Heat treated or otherwise special crating shall be supplied as required for international shipping or as otherwise requested upon purchase.



Do not stack crates during shipment

Standard packaging is intended to provide a rigid construction to prevent accidental impact when transporting the pumps/units. Unless otherwise requested and agreed upon by LobePro, this packaging shall not be weight-bearing and is not intended to support additional equipment stacked above.



Do not mount, transport, or store LobePro rotary lobe pumps on a slope more than 10 degrees from horizontal.

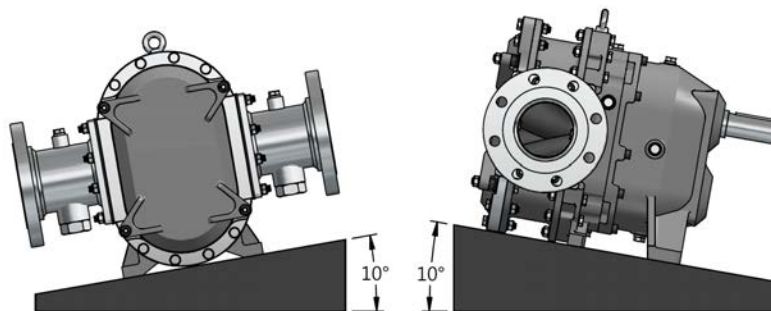

Fig. 4.1.1 Maximum mounting, transport, and storage angle (10 degrees)

Excessive storage angle increases the risk of toppling or other shifting of the pump or assembly, resulting in undue damage.

4.2 Receiving and Handling

Upon receipt of the pump/unit, the Record of Receipt shall be completed and returned to LobePro within 60 days of receipt of the pump/unit. As noted in warranty claims, warranty is not activated unless the Record of Receipt and Installation and Commissioning Record are received. A copy of these forms were provided with the pump, and sent electronically with the notification of shipment.

Pumps and baseplates are bolted to a rigid crate. The product should be unfastened from the crate prior to lifting the pump or baseplate. Be cautious of screws, bolts, nails, and straps during this process.

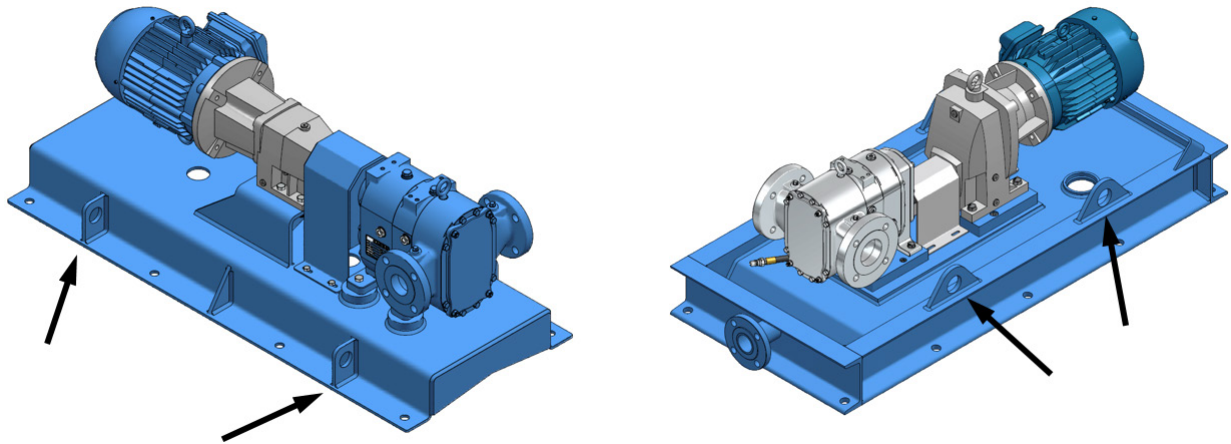

Fig. 4.2.1 Reference location for equipment and baseplate lifting lugs

Rotary lobe pumps and their installed components are heavy; follow all lifting and handling instructions shown on the crate and listed within this manual. **DO NOT USE THE PUMP OR MOTOR EYE BOLTS TO LIFT OR ADJUST THE BASEPLATE.** Baseplates are provided with four lifting lugs as a standard; other lifting provisions may be incorporated upon request. Failure to properly lift and/or support equipment can result in serious physical injury and/or equipment damage.



Crush hazard. Use proper lifting methods and wear steel-toed shoes at all times. Do not lift equipment overhead.

Pumps shall be lifted vertically, as shown in Fig. 4.2.2. Do not attach sling ropes to shaft ends and use only recommended and rated lifting devices. Refer to the pump specification and data sheets (Section 9) for the weight of each pump frame. Refer to project drawings and other provided information for the weight of the entire skid and other equipment, and the location of lifting points.

If the pump is to be installed and commissioned without storage, packing materials and other protective treatments shall be removed from the pump and disposed of in accordance with all local, government, and/or environmental regulations. These materials may include the use of desiccant packets or moisture-resistant wrapping of exposed steel shafts. If the pump shall be placed in storage, packing materials and treatments shall be replaced or reapplied after inspection, as appropriate. Flange and skid covers shall only be removed for the purpose of inspection, until ready for installation. Replace all covers prior to storing the pump.

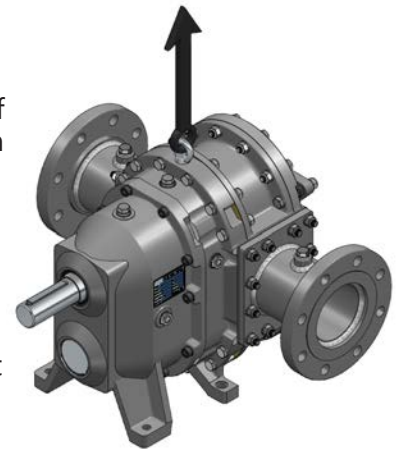

Fig. 4.2.2 Pump lifting eye reference location.

4.3 Storage Requirements

Note: These instructions are provided for the pump only; for all other equipment, refer to the instructions given by the original equipment manufacturer.

Sufficient storage methods are important to ensure that there is no deterioration of the pump due to moisture, dirt, dust, damage, or other adverse effects. Storage requirements depend on the duration of storage. If it is not possible to properly store the pump or skid in accordance with these recommendations, the risk of deterioration increases and is the responsibility of the end user. Unless otherwise noted, standard packaging is intended only to protect the pump during shipment.

If stored outdoors, ensure that the pump or skid is stored on a pallet, or otherwise stored off the ground, and properly covered to limit the risk of damage from ground/surface humidity. It is preferred to use a protective barrier between the pallet and pump/skid.



Any deterioration resulting from the end user's storage procedures, including any time during which the pump is installed but not in operation, is not covered by LobePro warranty.

Maintain a minimum clearance of one (1) foot around the pump or skid. For multi-level stocking, observe the recommended weight and height limitations of the shelf manufacturer. Always secure the pump or skid from sliding movement.

4.3.1 Temporary/Short Term Storage

Short term storage is defined as any duration of storage up to one (1) month (30 days). The pump shall be storage in a clean, dry location with slow/moderate changes in ambient temperature. Storage temperature shall be between 40 °F (4 °C) and 100 °F (38 °C). Skids may be stored outdoors provided these conditions are satisfied and the storage location is free from chemicals, flooding, and/or more than 5 inches of snow accumulation. If stored outdoors, do not remove the skid from the wood base; remove the wood base only prior to installation.



When stored or otherwise not in operation, the pump shafts shall be slowly rotated a minimum of two and a half (2.5) revolutions every one (1) month to re-lubricate bearings and seals, prevent corrosion and the seizing of the mechanical seal face, and ensure that the equipment will be in good operating condition when commissioned or returned to service. When the pump is coupled with other equipment, storage maintenance shall follow the most stringent requirements for maintenance. For example, some driver manufacturers require at least 5 revolutions per month, while others may have a longer maintenance period, longer than one month with a greater number or rotations. Please review all equipment manuals provided with your Installation and Maintenance Manual.

4.3.2 Long Term Storage

Long term storage is defined as any duration of storage in excess of one (1) month (30 days).

The pump shall be stored indoors, in a clean, dry location free from moisture, dust, and dirt. Storage temperature shall be between 40 °F (4 °C) and 100 °F (38 °C).



When stored or otherwise not in operation, the pump shafts shall be slowly rotated a minimum of two and a half (2.5) revolutions every one (1) month to re-lubricate bearings and seals, prevent corrosion and the seizing of the mechanical seal face, and ensure that the equipment will be in good operating condition when commissioned or returned to service. When the pump is coupled with other equipment, storage maintenance shall follow the most stringent requirements for maintenance. For example, some driver manufacturers require at least 5 revolutions per month, while others may have a longer maintenance period, longer than one month with a greater number or rotations. Please review all equipment manuals provided with your Installation and Maintenance Manual.

Storing after Operation

When removing the pump from storage, the pump cover shall be removed to completely empty the pump casing of all residual fluid. Depending on the pump service, additional flushing may be required. Cast iron pump frames require additional protection during storage; internal unpainted, or otherwise unprotected surfaces shall be cleaned with denatured alcohol, thoroughly dried, and coated with a rust inhibitor. In damp or humid environments, the pump casing shall be completely filled with rust inhibitor before storing.

The seal quench chamber and gear housing shall be flushed and refilled in accordance with LobePro lubrication recommendations (Section 8).

All exposed, unpainted surfaces (such as the pump drive shaft) shall be cleaned and coated with a rust inhibitor in accordance with the intended duration of storage.

Removal from Storage

If filled for storage, empty the pump casing of rust inhibitor, anti-freeze, or other fluids used for storage.

Inspect the seal quench chamber and gear housing for signs of leaks, moisture ingress, or other defects. Conduct a pressure test on the quench chamber and gear housing to check the integrity of the mechanical seals (Section 10.5); replace the mechanical seals and/or elastomers as necessary. Prior to start-up, flush and refill the seal quench chamber and gear housing in accordance with LobePro lubrication recommendations (Section 8).

Inspect the pump, driver, coupling, and other equipment for signs of damage or failure before returning the pump to service. If installed, verify that all gauges, sensors, and other monitoring equipment are functioning correctly.

Check the original equipment manufacturer's manuals for storage requirements for the motor, gear reducer, or other supplied equipment.

4.3.3 Cold Weather Storage

Cold weather storage shall be considered when there exists any potential for the storage temperature to fall within five (5) degrees of or below the freezing point.

The pump cover shall be removed to drain all fluid from the pump casing, including the suction and discharge flanges. The pump casing shall be filled with an environmentally-friendly anti-freeze in accordance with Table 4.3.

Table 4.3. Minimum volume of anti-freeze for cold weather storage

Pump Frame	Anti-freeze volume (quarts)	Pump Frame	Anti-freeze volume (quarts)
S8	0.2	M100	2.0
S16	0.4	L133*	2.7
M34	0.7	L266*	5.3
M50	1.0	L399*	8.0
M68	1.4	L531*	10.6

* Includes high pressure frame variants

After filling the pump casing with anti-freeze, rotate the pump five (5) full rotations to mix the anti-freeze with any residual fluid in the casing.

Flush and refill the seal quench chamber and gear housing in accordance with LobePro lubrication recommendations (Section 8).

5 INSTALLATION AND COMMISSIONING

5.1 Location and Clearances

LobePro pumps are designed for “maintenance in place”; this means that standard maintenance (replacing wear parts, oil changes, etc.) can be performed without removing the pump from the installation location, removing the pump nozzles, or uncoupling the pump from the driver. In order to facilitate this maintenance, the pump should be installed with ample space for access, inspection, maintenance, and ventilation. LobePro recommends a minimum clearance of three (3) feet from the pump cover, and two (2) feet from the edge of the skid.

For best performance and longevity, the pump should be installed as close as practical to the source of the fluid to be pumped. Suction piping shall be as short and straight as possible; bends shall be kept to a minimum. For applications exceeding 15 feet of lift, or those with longer or more intricate suction lines, it is recommended to contact LobePro engineering to verify that the pump will operate as intended and without detrimental effect.

5.2 Alignment and Mounting

All pumps and skids must be fastened to a solid base (concrete foundation, steel plate/bracket, etc.). The base should be suitable to withstand all loads occurring during operation, including upset conditions. The installation location shall meet all required conditions given in project drawings, if provided. Concrete foundations should have sufficient firmness to meet existing codes and standards to ensure a secure, functional mounting. LobePro skids are provided with grouting provisions, but do not require grouting. Contact LobePro for any questions in regard to installation and mounting, including the proper locations for drilled vent holes for grouting.

As stated in Section 5.1, sufficient space must be provided for maintenance and repair work, including room to remove and replace the driver or other equipment. The driver fan shall not have its ability to intake cool air impeded, and the fan guard shall not be blocked by any adjacent wall or equipment, and shall be easily accessible for inspection. Check with the original equipment manufacturer for proper installation clearances.

For all complete skids (pump and driver provided by LobePro), alignment must be checked prior to initial start-up and commissioning and after installation and grouting, if applicable.



Shaft alignment requirements shall be in accordance with the requirements of the original equipment manufacturer, and all applicable standards or codes for the installation.

Prior to alignment:

- Inspect the pump and driver shaft for any signs of damage or defect.
Note: LobePro rotary pump shafts are rectangular-keyed transmission
- Verify the motor direction of rotation for the direction of flow for the pump (Section 3.2)
- Ensure that the pump driver (and other equipment) is electrically isolated

The pump and driver shall be aligned at ambient temperature and shall be corrected to allow for thermal expansion at operating temperature. For applications with high fluid temperatures, the pump should be aligned at ambient temperature, then operated at the final operating temperature until oil temperatures have stabilized. The pump should then be shut down and the alignment should be re-checked immediately.



Ensure that the coupling/belt guard is replaced after checking alignment. The coupling/belt guard must be installed per Occupational Safety and Health Administration (OSHA) and other safety regulations to protect personnel from injury or death.

5.2.1 Alignment Methods

Pumps and drivers should be aligned, levelled, and coupled in accordance with standard shop practice and in accordance with the coupling/driver manufacturer's specifications. Ensure that the pump is not affected by undue pipe stress which may skew alignment. It is important to verify that components are properly aligned to prevent noise, excessive vibration, coupling wear, and excessive wear or failure of the pump bearings, seals, and other components.

Belt Drives (Overhead Motor/Piggyback)

Follow the recommendations and standard procedures for the belt and sheave/sprocket manufacturer when installing and checking belt tension. Belt tension and alignment shall be checked after the first five (5) operating hours following installation or return to service. Tension and alignment shall be rechecked every 500 operating hours thereafter.

Engine Drives

The engine and speed-reducing gearbox shall be mounted free from stress and excessive vibration at any load. Follow the engine manufacturer's recommended installation and operation instructions.

Other Drivers

For all other configurations, such as hydraulic motors, contact LobePro for recommendations before installation or operation.

5.3 Commissioning and Start-up

5.3.1 Pre-Commissioning Procedures

Pump Inspection

Prior to commissioning, the pump should be rotated by hand, with a strap wrench, or short tipping of the motor to ensure that the pump rotates easily. In cases of doubt, remove the pump cover to inspect the pump casing, lobes, and seals for any obstructions or deterioration. Note that, in hot or outdoor environments, the rubber lobes may adhere to the pump cover. This can be resolved by loosening the pump cover and then rotating the pump shaft. Contact LobePro for further assistance if necessary.

Grouting

If the pump skid is to be grouted, vent holes shall be drilled as necessary. Contact LobePro to verify the location of structural supports and recommended hole locations. Vent holes shall be resealed per standard contractor procedure or end-user recommendation, ensuring compatibility with the process fluid and operating environment. Ensure that the grout has reached its full cure time before tightening anchor bolts. After grouting and tightening the anchor bolts, ensure that the pump and motor alignment is checked per Section 5.2.

Lubrication

Check the oil level in the pump chamber at the chamber sight glasses in accordance with Section 8. Verify that gear reducer, if present, has sufficient oil. Refer to the original equipment manufacturer's manual for fill volume and the location of fill ports, drain plugs, and sight glasses, if provided.

Driver Inspection

Ensure that the driver is wired or otherwise assembled for the correct rotation and properly grounded. Refer to Section 3.3 for a comparison of shaft rotation to the direction of flow. After the driver is coupled to the pump, check for proper direction of rotation by jogging the motor or otherwise operating at very low speed.

If removing the equipment from long term storage, refer to the motor manufacturer's procedures for removal from storage.

Vacuum / Suction Tank

For pump(s) that include vacuum / suction tank, please review the following:

1. Ensure the vacuum tank is installed on the suction side of the pump.
2. Fill the vacuum tank with process fluid for self-priming when starting the pump for the first time.
3. When commissioning the pump, the vacuum relief valve must be adjusted to the site operating conditions in order to prevent any pump cavitation.
4. If the pump starts shaking or losing prime, the tank may be clogged. For tank cleaning, a cleanout port is located below the suction pipe connection.

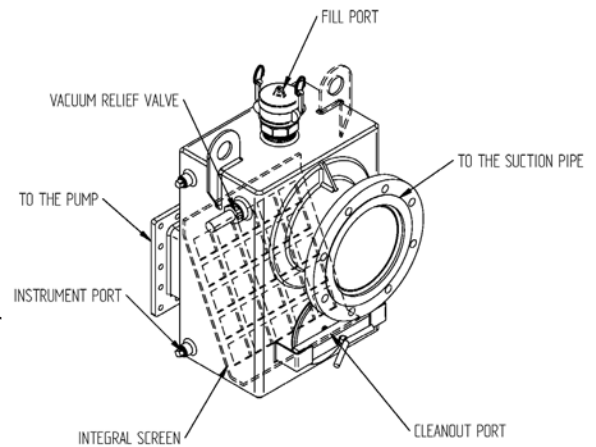

Fig. 5.1 - Reference Vacuum / Suction Tank
Actual design of the tank may be different.

Instrumentation, Valves, and Auxiliaries

Ensure that all gauges, meters, and other measurement devices are calibrated and ready for use, if applicable. Ensure that all control systems (manual or automatic) are approved and ready for use. Ensure that all valves to and from the pump are operational.

5.3.2 Commissioning Procedures



Refer to forms:

- QF-CD-01-03 LobePro Installation and Commissioning Record
- QF-CD-01-04 LobePro Commissioning and Service Schedule

Pump warranty is not activated until the LobePro Installation and Commissioning Record, QF-CD-01-03, is completed and returned to LobePro. See WARRANTY ACTIVATION and the Pump Warranty and Terms and Conditions packet supplied with your order.

The above forms provide an overview of our standard commissioning procedures, detailed below:

1. Ensure that all valves to the suction and discharge ports of the pump are open and that the lines are free from obstruction. This is a positive displacement pump; operation of the pump with blocked discharge piping may result in a rapid increase in pressure, which may result in equipment damage, personnel injury or death. Operation of the pump with a closed suction line may cause the pump to run dry, generating excessive heat and/or pressure which may result in component failure.
2. Verify that coupling/shaft alignment is within manufacturer tolerances (Section 5.2).
3. Verify that all equipment mounting bolts are securely tightened.
4. Ensure that the coupling guard is in place and securely tightened and that all other safety guards and protections are in place.
5. Fill the pump casing (and suction line as applicable) with the process fluid (or water, if appropriate). For applications with positive (flooded) suction pressure, open all valves to the pump. Nozzles on the pump casing or fittings may be used for this process. If provided, the vacuum/sediment tank can also retain fluid for this purpose. Note: A temporary piping system may be used to circulate water or other approved fluid for commissioning purposes only.
6. Start the motor at full speed (or speed sufficient for lift, contact LobePro Engineering for questions) and verify that the pump successfully primes. Priming may be signaled by a noticeable dampening of noise from the pump casing, as well as increasing discharge pressure.
7. Verify that the pump is producing proper pressure and/or flow. As a minimum safety precaution, all pumps should be installed with a pressure gauge. Check that the pump is producing flow by verifying the generation of a positive gauge reading.

8. Monitor the pressure gauges to ensure that:
 - a. The discharge pressure stabilizes. A rapid increase in pressure or sudden spike above the rated application pressure may indicate that there is a closed valve or other blockage in the line. Shut down the pump and inspect the line to ensure all valves are open and the line is clear. Fluctuating pressure may signal excessive vibration, accumulation of debris in the line, or excessive air or gas in the fluid (including cavitation).
 - b. The pump is not at risk of cavitating. Suction pressure will vary based on the application. Under normal operation (minimal lift), suction pressure shall generally be less than 10 inHg (-5 psiG).
9. Shut down the pump and check for any signs of leaks in the suction and discharge piping, leaks at the oil chambers, or any other signs of connection issues.
10. After waiting at least 10 minutes, restart the pump and verify that the pump primes and resumes normal operation without issue.



Follow all recommended safety instructions and procedures while performing this test. Only a qualified contractor or other designated personnel should conduct testing and commissioning of this pump.



After commissioning, ensure that the LobePro Installation and Commissioning Record, QF-CD-01-03, is completed and returned to LobePro to activate pump warranty.

6 TYPICAL CONFIGURATIONS

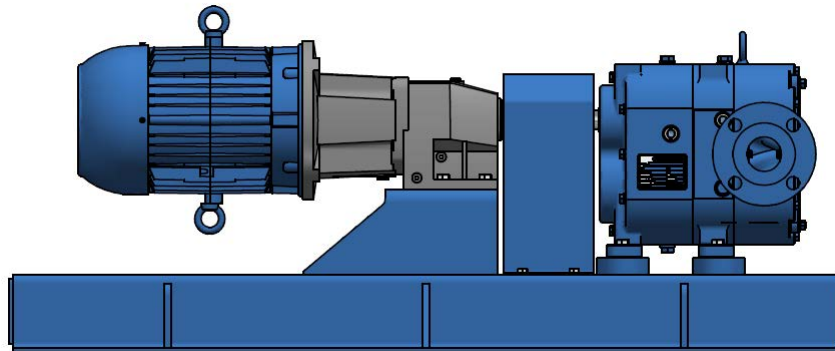

Fig. 6.1 Standard in-line configuration with electric motor and NEMA C-face gear reducer. Motor mounting will vary by motor size.

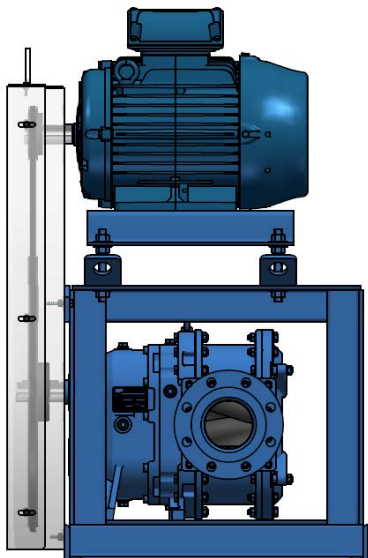

Fig. 6.2 "Piggyback" assembly - structural skid with overhead motor

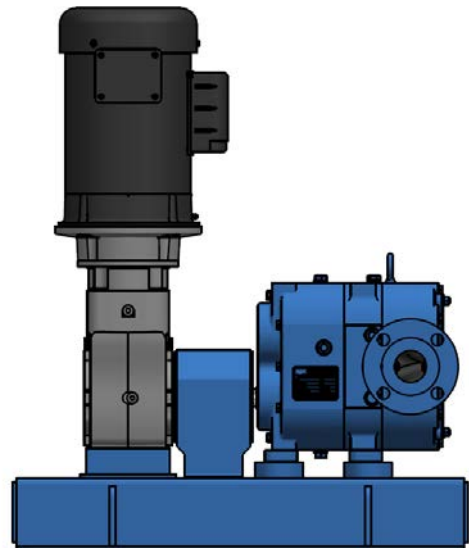

Fig. 6.3 Right angle gear motor. Availability may be restricted based upon motor size and output speed.

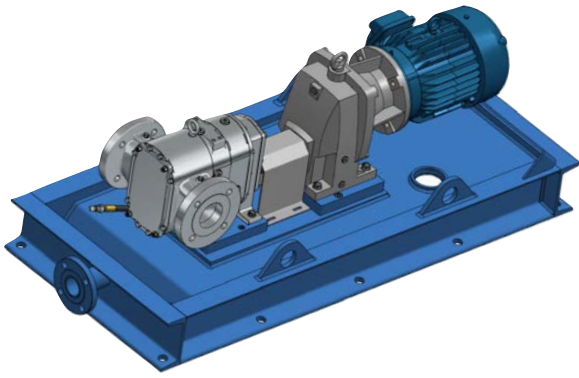

Fig. 6.4 API 676-rated structural baseplate with drain pan.

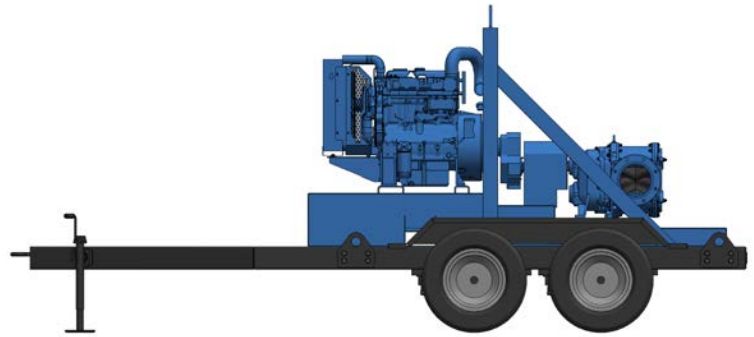

Fig. 6.5 Trailer-mounted skid assembly – electric motor or engine drive.

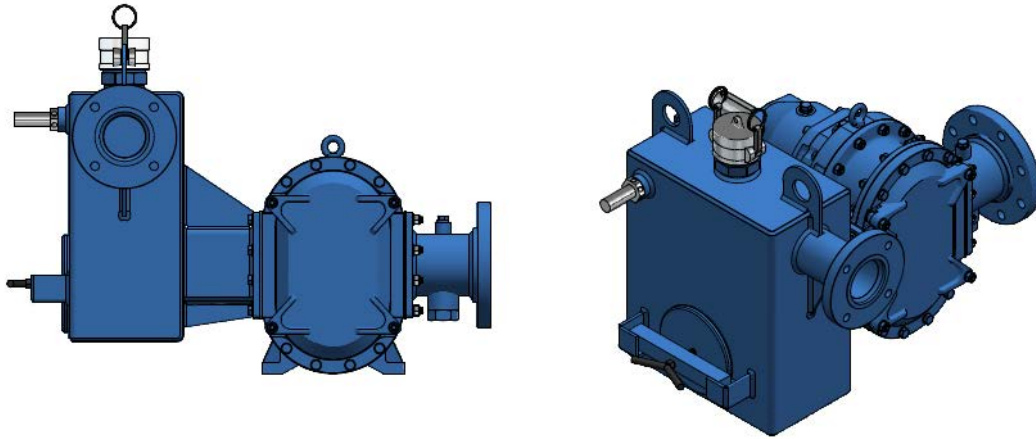

Fig. 6.6 Vacuum/sediment screening tank offer priming assistance for applications with larger lifts or those with large solids

Other Assembly Configurations

The above figures show typical configurations; LobePro rotary lobe pumps may be mounted in many various ways. Contact LobePro Engineering to discuss your application requirements for alternate assembly options.

Other configurations may include:

- Special pump transition fittings (90 degree, reduction, expansion, swan neck, etc.)
- Side mounting (vertical ports, vertical shaft, etc.)
- Process/structural skids
- Portable mounting
- Hydraulically-driven assemblies

Contact LobePro for all other pump positions and mounting other than horizontal.

Assembly Notes and Precautions

Pump drivers, such as engines, electric motors, hydraulic motors, and other equipment should only be installed by trained and authorized personnel. Installations must comply with the latest applicable national, local, and industry codes and standards.

All piping must be mounted free from stresses. Always verify that the pump and piping are free from unwanted/foreign materials and never use the pump to clear blocked piping or debris.

LobePro pumps are often used for suction lift application, but require wet priming. Contact LobePro is the maximum suction lift exceeds 25 feet (7.6 meters). This distance is measured from the centerline of the pump suction port to the surface of the fluid to be pumped. LobePro recommends the use of a vacuum/sediment tank or swan neck fitting to retain fluid above the pump centerline for priming.

LobePro pumps can operate in both directions; however, certain connections in the line, such as check valves, may prevent the use of this feature. Contact LobePro for recommended pipe fittings, instrumentation, valves, and other fixtures to be used.

7 PIPING SYSTEMS

The performance of the pump and system depend significantly on the correct size, origination, materials, connections, and overall design of the pipe system. LobePro standard fitting/pipe sizes are listed on each specification sheet (Section 9).

Improper design of the piping system may cause the pump to perform inefficiently, cause premature wear, or even damage the pump and associated equipment. Care must be taken to ensure that fluid can flow freely to and from the pump. Particular attention must be paid to ensure that the suction piping is airtight and that the Net Positive Inlet Pressure values are observed. For example, if the diameter of the intake/suction piping is too small, it may restrict the suction capability of the pump or even cause cavitation. If the diameter of the discharge piping is too small, it may cause excessive head loss leading to an undesirable increase in discharge pressure. Common negative effects of improper piping systems may include cavitation, excessive noise, excessive vibration, and seal or component failure. Contact LobePro for recommended pipe sizes.

LobePro recommends that the following notes be taken into consideration when designing the piping system and operating the pumps accordingly:

1. LobePro pumps are shipped with protective covers on all pipe connections to prevent debris from entering the pumps during transport and storage. Ensure that these covers are removed prior to connecting piping.
2. All equipment should be isolated from external sources of vibrations.
3. Valves, reducers, and other fittings shall be positioned at least 5 to 10 times the pipe diameter from the pump and other fittings.
4. If the piping system is full of process material and the pump has been idle for more than a day, care must be taken to flush the piping system prior to restarting the pump. While the pump is inactive, suspended solids in the fluid may settle out and accumulate in the piping. This can lead to a blockage in the piping, which can resist the suction or discharge lines, causing damage to the pump, equipment, or even personnel. Settled debris in the suction line may suddenly give way and enter the pump, causing undue damage to the lobes and/or seals, or failure of the entire pump.
5. When the process requires flushing, cleaning, or other actions which may pose a risk to the pump, LobePro recommends that the system include a bypass line so that the pump can be isolated.
6. When installing piping, ensure that the pump remains accessible for installation, maintenance, and disassembly. If expansion joints are used in the system, they must be supported in such a way that the allowable forces and moments on the pump fittings are not exceeded. Never rely on the pump as a support for piping. Do not mount expansion joints in such a way that their weight or other resulting forces may act on the pump flange.
7. Stress on the pump fittings may cause misalignment, excessive temperature build-up, worn couplings, vibration, and possible failure of the pump. When designing the piping system, take necessary precautions to not exceed maximum allowable strain. Allowable maximum forces and moments on the pump flanges and connections vary by pump size and materials. When any potential for excessive pipe stress exists, contact LobePro to verify the maximum allowable values and recommendations to minimize pipe stress.
8. Before start-up, the pipe system, fittings, and equipment must be clean and free from debris and other foreign objects,
9. If necessary to drain the piping system after testing or otherwise operating the pump, ensure that the pump and piping are completely drain and treated as necessary to prevent rust and corrosion or other issues which may affect start-up and system integrity.

8 LUBRICATION GUIDE

Proper lubrication is essential in order to reduce friction, heat, and component wear. In order to ensure the best operation and longevity of your pump, you should ensure that both the seal quench chamber and gear housing are regularly inspected and free from contamination. Contamination of the gear housing can lead to corrosion and oxidation of the bearings and gears, reduced mechanical efficiency, or even component failure. Contamination of the seal chamber can result in excessive heat or deterioration of the seal faces, O-rings, and lip seals, increasing the risk of contamination of the gear housing.

8.1 Standard Lubricants

Unless otherwise specified for the application, all LobePro rotary pumps are pre-filled with 80 W90 (ISO VG 220) oil.

Standard Oil: Chervon Delo Gear EP SAE 80Q-90 - 223022

Standard Synthetic Oil Option: Mobil SHC 630

Alternative Oils:

Total Carter EP 220

Shell Omala 220

BP Energol GR-XP 220

Castrol Alpha SP 220

Standard Grease (Lh-frame): SKF LGHB 2

Please consult LobePro for all operational speeds above the pump's rated speed (rpm) and temperatures above 250 °F (120 °C).

8.2 Oil Inspection

Inspect the oil in the quench chamber and gear housing after the first 24 operating hours, and then after every 200 operating hours.

Inspection should include the following steps:

1. Verify oil level is visible at each of the provided sight glasses
2. Inspect oil for signs of contamination
3. Refill or drain excess oil as needed; only use clean, unused oil. Do not overfill the quench chamber or gear housing; the resulting air pocket provides a buffer for oil expansion as the chamber temperature increases.

Inspection should occur when the pump is operating, or within one half hour (30 minutes) following shutdown; this ensures the oil is inspected before contaminants have settled out. It is common for the gear housing oil to appear "frothy" or of a lighter color during operation; this a result of the aeration that occurs in splash lubrication.



8.3 Filling and Draining the Oil

Oil must be changed for both the seal quench chamber and gear housing if either show signs of contamination.

All LobePro pumps are assembled with oil fill and drain plugs and sight glasses in their proper locations corresponding to the final operating position. All standard plugs are metric (M16 x 1.5) and utilize a bonded seal washer or similar sealing surface between the plug and casing.

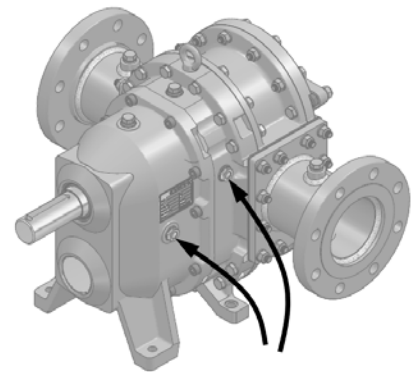

Fig. 8.1 Oil level sight glass location

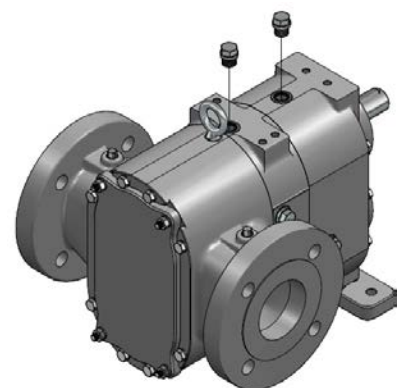

Fig. 8.2 Reference oil fill plug locations

Drain and fill plugs are provided in steel (hex head) and stainless steel (socket head) versions, in accordance with the pump series and operating environment. When refilling the seal quench chamber and gear housing, you should fill each chamber until the oil is visible in the sight glass, shown in Fig. 8.1.

When first operating the pump after refilling the oil, it is common to notice a significant drop in the oil visible in the sight glass of the gear housing. This is an effect of the splash lubrication used to lubricate the timing gears and bearings. It is acceptable to add additional oil to this chamber to make-up the difference but care must be taken to maintain the air gap within this chamber.

As the temperature of the oil chamber rises, the oil will expand, compressing the air inside the chamber and thereby generating chamber pressure. Because air is much more easily compressed than a liquid, the presence of the air gap keeps this pressure increase low. Without the air gap, chamber pressure would increase much more rapidly and compromise the shaft lip seal, drain plug seals, or even the chamber O-ring seal.

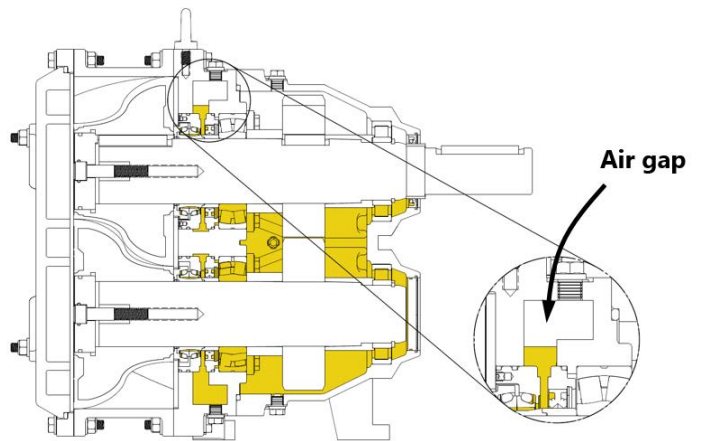

Fig. 8.3 Oil chamber air gap



Do not operate this pump with either chamber overfilled. Normal operating temperatures may cause the excessive pressure generation which may pose an environmental and safety risk.



Ensure that all fill and drain plugs and sight glasses are installed and tightened prior to returning the pump to service.



Ensure that all oil level, temperature, pressure, and moisture sensors or switches, if used, are functional prior to returning the pump to service.

The base assembly for a LobePro pump features standard plugs for draining the seal quench chamber and gear housing. Unfortunately, use of these plugs will require that the pump be removed from its baseplate each time the oil is changed, or that the baseplate and installation site are adjusted to accommodate removing these plugs in-place.

Because it is often impractical to remove the pump from its baseplate each time the oil needs to be drained, LobePro offers an oil drain hose assembly with a quick disconnect nozzle. These hoses may be used to drain or fill the seal quench chamber and gear housing.

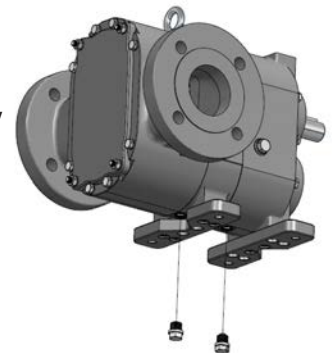

Fig. 8.4 Reference oil drain plug locations

Standard hose assemblies feature a 3/8" flexible rubber fuel hose and a swivel elbow, with steel adapters and brass ferrules. Alternate assemblies and materials of construction for corrosive environments may be available depending on the application. Contact LobePro for further information.

When installing drain hoses on an older pump:

1. Inspect the drain hose assembly (Fig. 8.5) for any signs of defect or damage. Ensure that the length of the hose meets requirements for free space for the application. Contact LobePro if your installation requires a different hose length (Standard length is 12 inches).
2. Remove the bottom drain plugs as shown in Fig. 8.4. The drain plugs may be set aside for future use, or discarded.

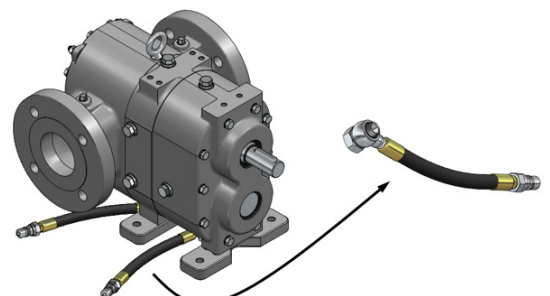

Fig. 8.5 Pump with oil drain hose assemblies

3. Install the drain hose assembly in the threaded holes beneath the seal quench chamber and gear housing. Adjust the flexible drain hose to its desired location prior to completely tightening the connection.
4. After installing the drain hoses, inspect the casing for any signs of leaks.
5. Ensure that both chambers are filled to the recommended oil level, visible at the sight glass for each chamber. See Section 4 for recommended oil volumes. After filling each chamber, verify that the oil level remains steady for at least 10 minutes to ensure the system is free from leaks. During this time, slowly rotate the pump drive shaft at least two full rotations. Alternatively, a pressure test may be conducted, as shown in Section 10.5.

Note: For older assemblies, ensure that there is sufficient space beneath the pump casing to install the drain hose assembly (2 inches recommended).

8.4 Lubrication Volumes

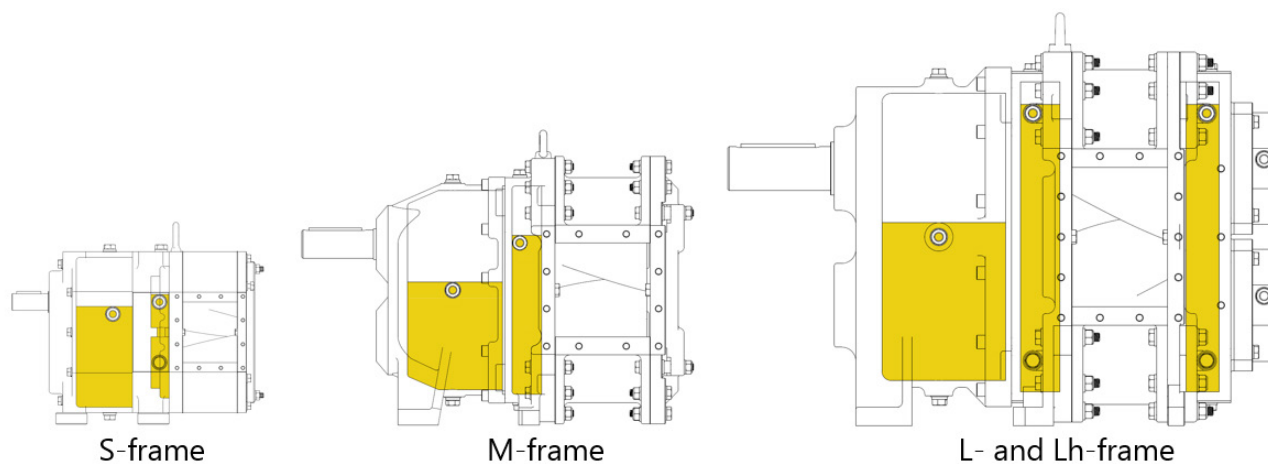

Fig. 8.6 Oil fill volumes by frame size showing gear housing (left) and seal quench chamber(s) (right).
 Note: Quench chamber volumes are identical for the Lh-frame assembly.
 High pressure door and oil chamber only present on Lh-frame assemblies.

Frame Size	Reference Oil Volume	
	Seal Quench Chamber	Gear Housing
S-frame	0.10 gallons (0.38 liters)	0.40 gallons (1.50 liters)
M-frame	0.37 gallons (1.40 liters)	0.60 gallons (2.25 liters)
L-frame	0.55 gallons (2.10 liters)	1.00 gallon (3.78 liters)
Lh-frame Door	0.55 gallons (2.10 liters)	7 to 10 fl. oz. (207 to 296 milliliters)

8.5 Maintenance Frequency

The oil in quench chamber and gear housing should be inspected every 200 hours and changed every 1000 operating hours or every 6 months (whichever occurs first), when there are signs of contamination, or as otherwise recommended based upon pump operation and process parameters.

8.6 Causes of Contamination

Contamination may occur in either chamber, independent of each other, or in both, depending on the cause of failure and any continued operation. The following sections will cover some potential causes of contamination so that they may be best avoided.

Quench Chamber Only

1. Mechanical seal failure: may be caused by failure of the mechanical seal faces due to general wear and operation, or prematurely due to the effect of contaminants or damage during installation, improper installation, defects, high temperature, excessive vibration, operation under excessive pressure, or operation of the pump in services other than what was recommended by LobePro.
2. Secondary seal failure: may be caused by improper seating/installation of the secondary O-rings, high temperature, material incompatibility, or operation under excessive pressure.

Gear Housing Only

1. Shaft O-ring failure: may be caused by damage during installation, material incompatibility, high temperature, material incompatibility, or operation under excessive pressure.
2. Moisture ingress: may occur at any of the fill and drain ports, sight glasses, or the shaft lip seal.
3. Excessive oil volume: when operating at high temperatures, the oil will expand and generate higher pressures which may cause failure at the shaft lip seal, mechanical seal lip seals, or the mating location of the quench chamber and gear housing.

Both Chambers

When both chambers show signs of contamination, failure is typically linear, starting in the quench chamber and continuing to the gear housing after continued operation. The most common cause for this failure is excessive pressures in the pump casing, though it may also be caused by high temperature and material incompatibility, among other factors.

8.7 Flushing after Contamination

If there are signs of contamination in the seal quench chamber(s) or gear housing, both chambers should be completely drained of oil, then refilled and allowed to sit for a period of at least thirty minutes. Then flush and inspect the chamber oil. Repeat this process until the oil is absent of any trace of contamination, then refill the oil of each chamber to the level of the sight glass, or as listed in Table 1.

For cases of severe contamination for which there are concerns of damage to the bearings, gears, or casing, contact LobePro for additional directions.

8.8 Cleaning and Replacing Bearing Grease (Lh-frame Only)

It is recommended that the bearing grease be removed and replaced each time the high pressure door assembly is removed and reinstalled; however, it may be impractical to remove the door assembly if only the bearing grease has been contaminated. Refer to the following steps to replace the bearing grease without removing the door assembly.

1. Unfasten the hex head bolts from the bearing cover and remove each cover. The standard pump assembly uses grease inside the bearing covers, which should be replaced each time the cover is removed and reinstalled. If oil has been used instead, use the side drain plug to drain the oil prior to removal.



Before removing the high pressure door assembly or any components, ensure that all oil chambers have been thoroughly drained.

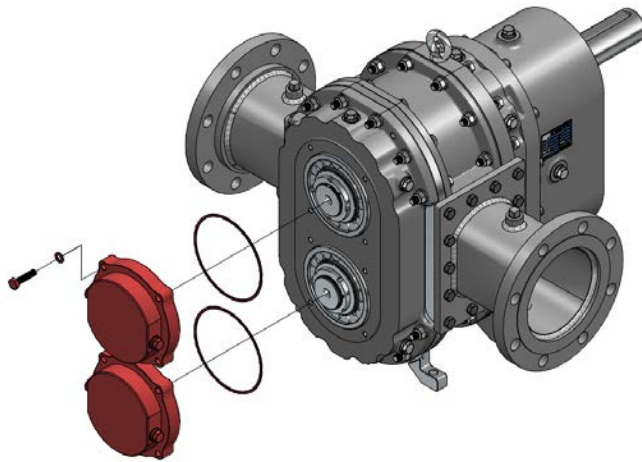

Reference Part No.:

91, 92, 93, 98

Reference Tool Sizes:

17 mm wrench/socket

Fig. 8.8.1 Removal of the bearing covers

2. Using dry, compressed air and a lint-free cloth, clear away the existing grease on the bearing rollers. Avoid using solvents or other chemicals which may be incompatible with internal elastomers (seal lip seal and O-rings). Ensure that the bearing covers and sight glass are also clean and free from old grease and contaminants. Contact LobePro for any questions.



Do not rotate the pump shafts after removing the bearing grease.

3. As listed in Section 8.4, packing the bearing rollers with 7 to 10 fl. oz. of bearing grease (SKF LGHB 2 – Equal or alternate acceptable with LobePro approval), ensuring even distribution. Residual grease may also be added into the bearing covers.
4. Place one cover O-ring around the exterior of each bearing. Ensure that the O-ring is fully positioned against the surface of the high pressure door and is not rolled or otherwise damaged.
5. Install the bearing covers onto the pump, taking care not to pinch or otherwise damage the O-ring installed in Step 19. Fasten each cover with the four hex head bolts and cap screws, torqued to 35 ft-lbs.



9 MAINTENANCE TOOLS & KITS

9.1 Recommended Standard Tools for Maintenance



LobePro offers a pre-assembled toolkit for each pump frame which includes all LobePro specialty tools for pump maintenance, as well as a few standard tools such as an O-ring pick and hex key set. However, LobePro does not offer wrench sets and other similar tools. For ease of reference, standard tool sizes needed for maintenance are included below, in addition to a description of their purpose for maintenance.

Refer to Section 9.2 for a full listing of the LobePro toolkits and the items included.



9.1.1 S-frame Tool List

	Combination / Socket Wrench	10 mm 13 mm 17 mm 19 mm	Wear plate mounting bolts Transition fitting bolts Frame bolts and cover nuts Lobe puller arm bolts Drain plug / hose (steel) Lobe puller threaded stud
	Nut driver	5.5 mm	Seal removal bolts
	Hex key/Socket adapter	1.5 mm 8 mm	Seal holder set screws Strain bolts Adjustable pump mounting feet Drain plugs (stainless steel)



9.1.2 M-frame Tool List

	Combination / Socket Wrench	17 mm 19 mm 9/16" (14 mm) 15/16" (24 mm)	Wear plate mounting bolts Frame bolts and cover nuts Transition fitting bolts Drain plug / hose (steel) Lobe puller arm bolts Lobe puller threaded stud
	Nut driver	8 mm	Seal removal bolts
	Hex key/Socket adapter	2.5 mm 4 mm 8 mm 14 mm	Seal holder set screws Pressure disc set screws Gear housing bolts Drain plugs (stainless steel) Strain Bolts

9.1.3 L-frame Tool List

	Combination / Socket Wrench	13 mm 17 mm 19 mm 9/16" (14 mm) 1-5/16" (34 mm)	Pressure disc removal bolts Wear plate mounting bolts Transition fitting bolts Frame bolts and cover nuts Drain plug / hose (steel) Lobe puller arm bolts Lobe puller threaded stud
	Nut driver	10 mm	Seal removal bolts
	Hex key/Socket adapter	2.5 mm 4 mm 8 mm 10 mm 14 mm	Seal holder set screws Pressure disc set screws Drain plugs (stainless steel) Gear housing bolts Strain Bolts

9.1.4 Lh-frame Tool List

	Combination / Socket Wrench	17 mm 19 mm 9/16" (14 mm) 1-5/16" (34 mm)	Wear plate mounting bolts Transition fitting bolts Frame bolts and cover nuts Drain plug / hose (steel) Lobe puller arm bolts Lobe puller threaded stud
	Nut driver	7 mm 10 mm	Lobe spacer removal bolts Seal removal bolts
	Hex key/Socket adapter	2 mm 3 mm 4 mm 8 mm 10 mm	Lobe spacer set screws Bearing lock nut set screw Seal holder set screws Shaft sleeve set screws Drain plugs (stainless steel) Gear housing bolts

9.2 LobePro Toolkits

9.2.1 S-frame Tool Box



No.	Tool Name	Qty.	Standard Dimensions	Description
1	Tool.SToolBox	1	18.50 x 8.25 x 8.67 in, 4.50 lb	Stainless steel toolbox with polypropylene base, tray, and lid. Maximum load: 55 lbs
2	Tool.Loctite-Tube	1	1 oz	Loctite LB 8009 metal-free anti-seize compound
3	Tool.OringPick	1		Carbon steel O-ring pick with plastic handle
4	Tool.RMallet-1.5lb	1	10.5 in, 1.5 lbs	Rubber mallet with wood handle
5	Tool.StrainSSocket	1	1/2" drive, 8 mm	Hex bit socket for strain bolt installation and removal
6	Tool.HexKey.S	1	1.5 mm	Hex key screwdriver

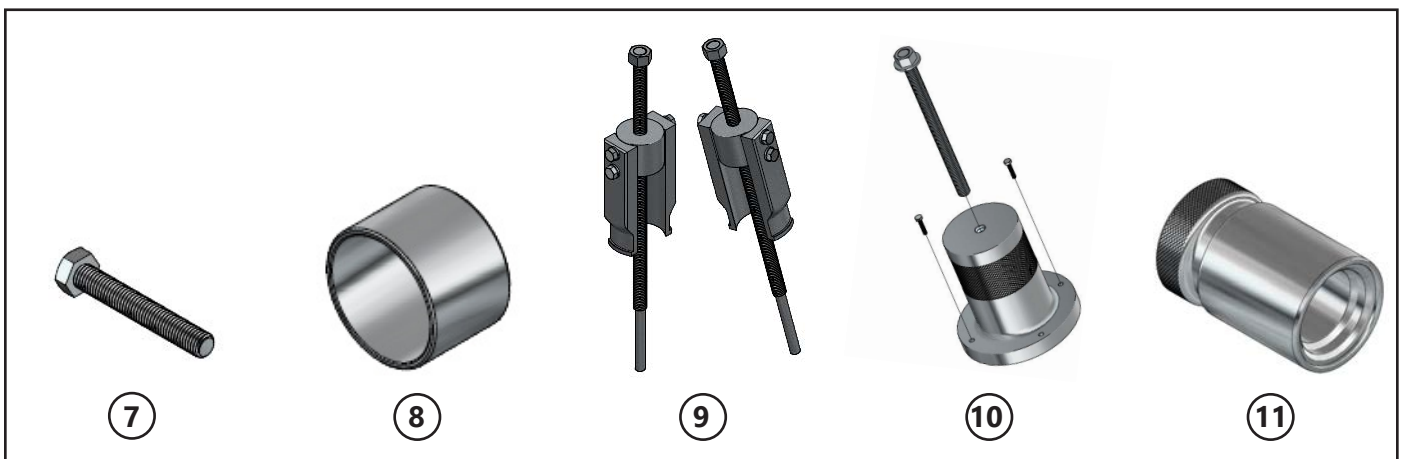

No.	Tool Name	Qty.	Standard Dimensions	Description
7	BoltL.HH.M12x80.S	1	M12 x 1.75 x 80	Hex head bolt for pressure disc removal, steel
8	RaceSIR	1		Hardened race for shaft O-ring installation
9	Tool.LobePullS.BN	1 or 2	M12 x 1.75 stud M10 x 1.5 x 20 bolts	Lobe removal tool. 1 piece per standard tool kit; 2 pieces for pro-series tool kit.
10	Tool.SealAlignS.BN	1	M10 x 1.5 stud M3 x 0.5 x 16 bolts	Seal installation and removal tool
11	Tool.SSealFacePusher	1		Face seal installation tool

9.2.2 M-frame Tool Box



No.	Tool Name	Qty.	Standard Dimensions	Description
1	Tool.MToolBox	1	22.6 x 12.1 x 10.5 in 7.0 lbs	Structural foam water resistant toolbox
2	Tool.Loctite-Tube	1	1 oz	Loctite LB 8009 metal-free anti-seize compound
3	Tool.OringPick	1		Steel O-ring pick with plastic handle
4	Tool.RMallet-2lb	1	10.37 in, 2 lbs	Rubber mallet with wood handle
5	Tool.StrainLMSocket	1	½" drive, 14 mm	Hex bit socket for strain bolt installation and removal
6	Tool.HexKey.LM	1	2, 2.5, 3, 4, 5, 6, 8 mm	Folding hex key set



No.	Tool Name	Qty.	Standard Dimensions	Description
7	BoltS.HH.M8x110.S	2	M8 x 1.25 x 110	Hex head bolts for pressure disc removal
8	SpacMC.S	1		Steel ring for shaft O-ring installation
9	Tool.LobePullM.BN	1 or 2	5/8" – 11 stud 3/8" – 16 bolt	Lobe removal tool. 1 piece per standard tool kit; 2 pieces for pro-series tool kit.
10	Tool.SealAlignM.BN	1		Seal installation tool
11	Tool.Cart.PullM.BN	1	M10 x 1.5 x 80 bolt M5 x .8 x 25 bolt/nut	Seal removal tool
12	Tool.MSealFacePusher.BN	1		Face seal installation tool
13*	Tool.SealAlignM.LK3.S.BN	1		Tabbed seal alignment tool

* included in Tool kits for pumps with tabbed seals only.

9.2.3 L-frame Tool Box



No.	Tool Name	Qty.	Standard Dimensions	Description
1	Tool.LToolBox	1	28 x 12 x 11 in 11.6 lbs	Structural foam water resistant toolbox
2	Tool.Loctite-Tube	1	1 oz	Loctite LB 8009 metal-free anti-seize compound
3	Tool.OringPick	1		Steel O-ring pick with plastic handle
4	Tool.RMallet-2lb	1	10.37 in, 2 lbs	Rubber mallet with wood handle
5	Tool.StrainLMSocket	1	½" drive, 14 mm	Hex bit socket for strain bolt installation and removal
6	Tool.HexKey.LM	1	2, 2.5, 3, 4, 5, 6, 8 mm	Folding hex key set

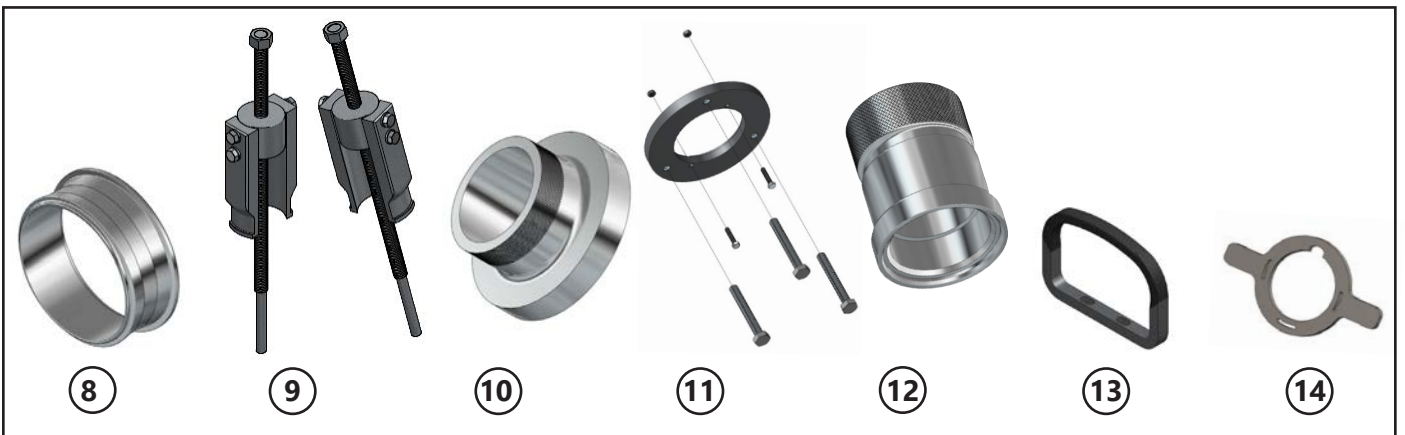

No.	Tool Name	Qty.	Standard Dimensions	Description
7	BoltS.HH.M8x110.S	2	M8 x 1.25 x 110	Hex head bolts for pressure disc removal
8	SpacLC.NW.S	1		Steel ring for shaft O-ring installation
9	Tool.LobePullL133-L266 / Tool.LobePullL399-531	1 or 2	7/8" – 9 stud 3/8" – 16 bolt	Lobe removal tool. 1 piece per standard tool kit; 2 pieces for pro-series tool kit.
10	Tool.SealAlignL.BN	1		Seal installation tool
11	Tool.CartPullL.BN	1	M10 x 1.5 x 80 bolt M6 x 1.0 x 25 bolt/nut	Seal removal tool
12	Tool.LSealFacePusher.BN	1		Face seal installation tool
13	Tool.PDRemover.LM.S	1		Pressure disc removal / alignment tool
14*	Tool.SealAlignL.LK3S.BN			Tabbed seal alignment tool

* Included in Tool kits for pumps with tabbed seals only.

9.2.4 Lh-frame Tool Box



No.	Tool Name	Qty.	Standard Dimensions	Description
1	Tool.LToolBox	1	28 x 12 x 11 in 11.6 lbs	Structural foam water resistant toolbox
2	Tool.Loctite-Tube	1	1 oz	Loctite LB 8009 metal-free anti-seize compound
3	Tool.OringPick	1		Steel O-ring pick with plastic handle
4	Tool.RMallet-2lb	1	10.37 in, 2 lbs	Rubber mallet with wood handle
5	Tool.LhDoorSocket	1	TMFS-12	Axial lock nut socket
6	Tool.HexKey.LM	1	2, 2.5, 3, 4, 5, 6, 8 mm	Folding hex key set
7	BoltLh.M4x.7x20.S	2	M4 x 0.7 x 20	Lobe spacer removal bolts

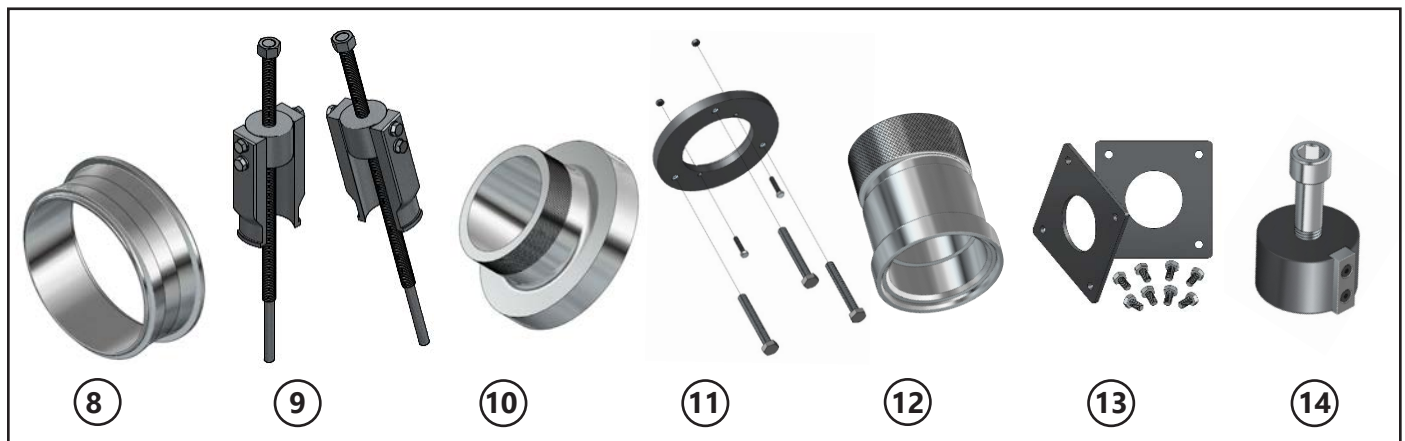

No.	Tool Name	Qty.	Standard Dimensions	Description
8	SpaLC.NW.S	1		Steel ring for shaft O-ring installation
9	Tool.LobePullL133-L266 / Tool.LobePullL399-531	1 / 2	7/8" – 9 stud 3/8" – 16 bolt	Lobe removal tool. 1 piece per standard tool kit; 2 pieces for pro-series tool kit.
10	Tool.SealAlignL.EN	1		Seal installation tool
11	Tool.CartPullL.EN	1	M10 x 1.5 x 80 bolt M6 x 1.0 x 25 bolt/nut	Seal removal tool
12	Tool.LSealFacePusher.BN	1		Face seal installation tool
13	BgRrLh.S	2	M10 x 1.5 x 30 bolts	Bearing/sleeve locking plates
14	Tool.SleeveAlign.Lh.S	1	M16 x 2 bolt	Sleeve alignment tool
15*	Tool.SealAlignL.LK3S.BN			Tabbed seal alignment tool

* Not picture. Included in Tool kits for pumps with tabbed seals only.

10 PUMP MAINTENANCE GUIDE



The actual pump frame and appearance will vary by frame size and materials of construction, but the procedure for replacing wear parts remains the same. For the purpose of brevity, this section will focus on the M-frame assembly. Alternate assemblies may be shown where significant differences occur.

LobePro pumps offer “maintenance-in-place,” which means that standard wear parts may be replaced without removing the pump from its installation location, provided that there is sufficient space for maintenance. The procedures below will provide step-by-step instructions for removing and reinstalling standard wear parts.

Refer to the pump’s bill of materials and exploded and section views for reference part names and numbers.

Refer to Section 10.3 for instructions on maintaining the high pressure Lh-frame assemblies.



Follow all safety notes and instructions specified in Section 1 before and throughout the maintenance process.



Always ensure that the pump is electrically isolated or locked out before beginning any maintenance procedures.



If maintenance requires removing the lobes or seals, ensure that the quench chamber and gear housing are depressurized by loosening or removing the fill plugs, and that the oil is drained accordingly.



This manual will only cover replacement of standard wear parts. For all maintenance affecting the frame/casing or gear housing, contact LobePro before beginning maintenance.

10.1 Pump Disassembly

10.1.1 Removing the Pump Cover

1. Before removing the pump cover, ensure that all suction and discharge piping leading to the pump is empty or that all valves immediately leading to the pump are closed. Otherwise the entirety of the contents of the piping will drain through the pump casing once the cover is removed.
2. Unfasten and remove the four cover lock nuts and washers. Replace any damaged or worn fasteners as necessary.

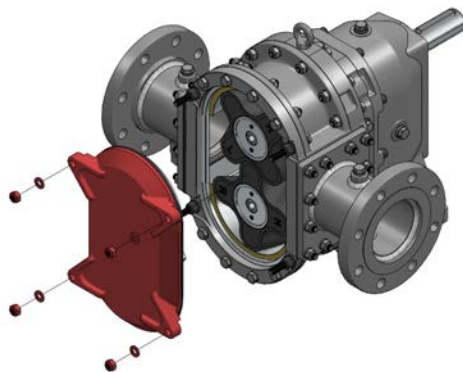

Reference Part No.:

S-frame: 28, 63, 81

M-, L-frame: 50, 63, 65

Reference Tool Sizes:

S-frame: 13 mm

M-frame: 17 mm

L-frame: 19 mm

Fig. 10.1.1 Removal of the pump cover (standard frame only)

3. Remove the pump cover by lifting slightly and pulling the cover away from the pump frame. The cover O-ring may or may not travel with the cover; inspect the O-ring for signs of damage or compression set of this O-ring and replace accordingly.



Use caution when removing the pump cover. The cover, including the wear plate, may weigh up to 60 lbs., depending on the pump frame.

10.1.2 Removing the Cover (No-hole) Wear Plate

If the wear plate is in acceptable condition, the wear plate does not need to be removed and these steps may be skipped.



LobePro wear plates are reversible; if showing signs of scoring, gouging or similar wear, the wear plate may be flipped rather than replaced. If the wear plate has lost much of its thickness due to abrasion, replacing the wear plate may be necessary to regain flow.

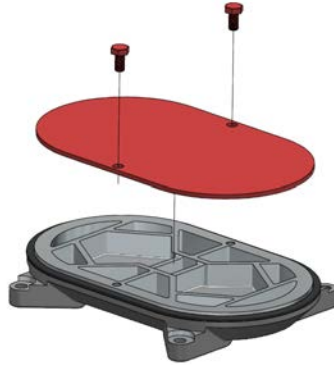

Reference Part No.:

S-frame: 27, 80
M-, L-frame: 48, 68

Reference Tool Sizes:

S-frame: 10 mm
M-, L-frame: 17 mm

Fig. 10.1.2 Removal of the pump cover wear plate (standard frame only)

1. After removing the pump cover, set it on a flat surface with the cover wear plate facing upward.
2. Unfasten and remove the two (2) wear plate mounting bolts, bracing the cover as necessary. Discard these bolts; each wear plate kit includes a new set of mounting bolts.
3. Remove the cover wear plate and set aside for re-use or discard the wear plate as appropriate.

10.1.3 Removing the Lobes



Before removing the strain bolts, lobes, or other pump components, ensure that all oil chambers have been thoroughly drained.

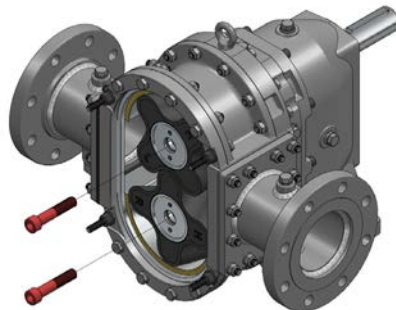

Reference Part No.:

S-frame: 60
M-, L-frame: 47

Reference Tool Sizes:

S-frame: 8 mm
M-, L-frame: 14 mm

Fig. 10.1.3.1 Strain bolt removal

1. Remove and discard the strain bolts from each shaft. These shall be replaced each time they are removed. To prevent shaft rotation, insert a rag or other compressible object between lobe tips as show in Fig. 10.1.3.2.

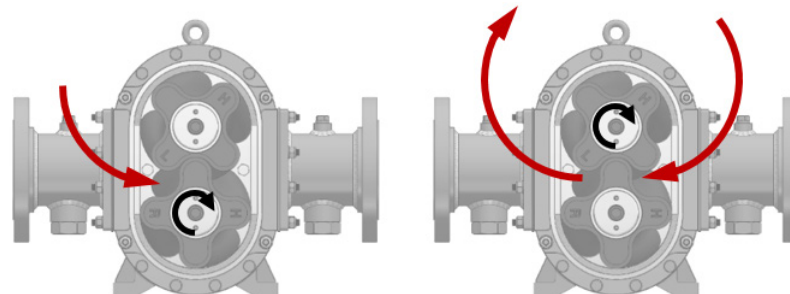

A

B

Fig 10.1.3.2 Blocking lobe rotation to unfasten strain bolts

- Unfasten the strain bolt on the top shaft. Depending on the frame size and shaft torque, the shaft may rotate before the bolt begins to loosen. As the shaft rotates, it will pull the rag/object through until the shafts lock and are unable to rotate further. Make sure that your hands are clear of the lobes during this process.
- Unfasten the strain bolt on the bottom shaft. As with step 2, the shafts may begin to rotate in the opposite direction. Move the rag/object to the opposite side of the lobes as necessary to lock the shafts and remove the second strain bolt. At this time, the rag/object may become stuck; it will be removed with the lobes, or when the new strain bolts are installed (Section 10.2.2).

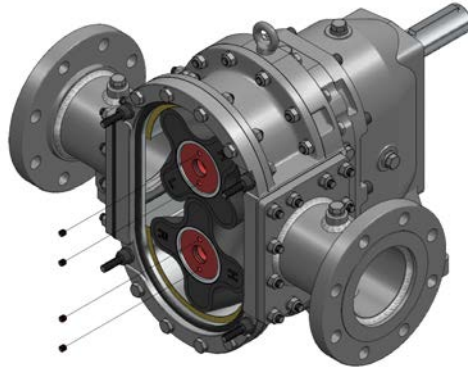

Reference Part No.:

S-frame: N/A
M-, L-frame: 44

Reference Tool Sizes:

S-frame: N/A
M-, L-frame: 4 mm

Fig. 10.1.3.3 Pressure disc set screw removal

- (L- and M-frame only) Remove the pressure disc set screws and set aside.

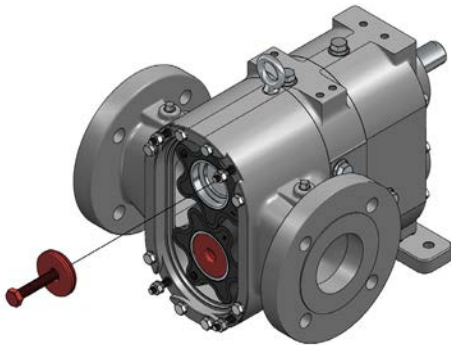

Reference Part No.:

S-frame: 56 - 59
M-, L-frame: 42 - 46

Reference Tool Sizes:

S-frame: M12 x 1.75 bolt
M-, L-frame: M8 x 1.25 bolt

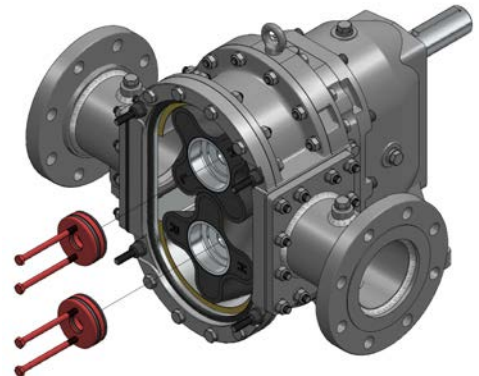
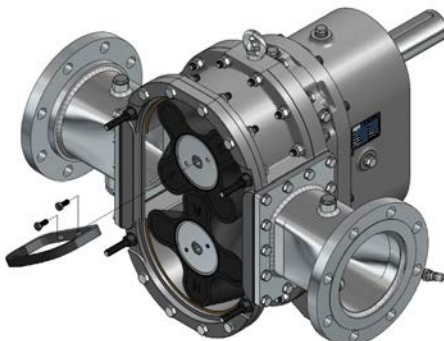

Fig. 10.1.3.4 Removal of the pressure disc assembly

- (S-frame Only) Fasten one (1) M12 x 1.75 bolt into the center of the pressure disc assembly and pull the assembly from the lobe core.

(M- and L-frame Only) Fasten two (2) M8 x 1.25 (5/16" - 18) bolts into the two set screw holes of the pressure disc. Pull the assembly from the lobe core. If necessary, use the bolts to slowly twist the assembly as you pull.



Reference Tool Sizes:

L-frame: 13 mm wrench

Fig. 10.1.3.5 Installation of the pressure disc removal tool

(L-frame Only) As an alternative, the L-frame tool box includes a removal tool to provide a better grip during removal (and aid in the reinstallation and alignment). Align the tool with the pressure disc threads and install two M8 x 20 bolts and pull to remove each pressure disc.

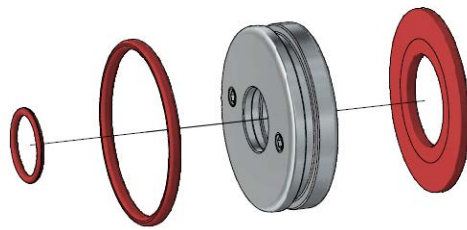

Reference Part No.:
 S-frame: 57, 58, 59
 M-, L-frame: 42*, 43, 45, 46
 * M-frame Only

Fig. 10.1.3.5 Removal of spring washer (S-, M-frame Only) and pressure disc O-rings

6. Remove the Belleville spring washer from the pressure disc (S-frame and M-frame only) as well as the interior and exterior O-rings; these should be replaced each time the pressure disc is removed. Clean the pressure disc and inspect for signs of damage or deterioration and set the pressure discs aside for reinstallation as applicable.
7. Ensure that the bore of the lobe core is free from contamination or debris.

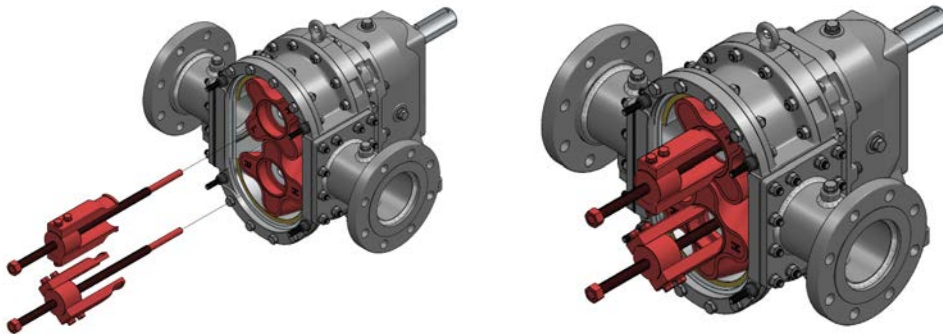

Reference Tool Sizes:
 S-frame: 17 mm wrench
 19 mm wrench
 M-frame: 9/16" wrench
 15/16" wrench
 L-, Lh-frame: 9/16" wrench
 1-5/16" wrench

Fig. 10.1.3.6 Installation of lobe puller tool(s) for lobe removal

8. Prepare the lobe puller tool(s) for use. Loosen the hex head cap screws on each arm so that the arm is free to pivot inward. Back out the center stud bolt to ensure that the tool can be fully positioned inside the lobe core.
9. Slowly tighten (rotate clockwise) the center stud so that the stud moves into the shaft. Continue to tighten the stud until the lobe begins to move out from the pump. Due to the helical design of the lobes, they cannot be removed independently and must be tightened incrementally in an alternating pattern between the two lobes. Note: This process can be done with a single tool, but requires that the tool switch between the two lobes. LobePro therefore recommends having two lobe puller tools for each frame size.

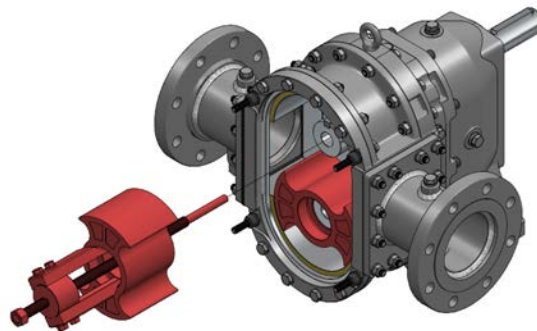



10.1.3.7 Removal of the two-wing "hammerhead" lobe

The lobe removal process is essentially the same for the two-wing style lobe, and other straight-wing lobes, with the exception that the lobes can be removed independent of each other.

10.1.4 Removing the Quench Chamber (Shaft Hole) Wear Plate

If the wear plate is in acceptable condition and the seals do not need to be replaced, the wear plate does not need to be removed and these steps may be skipped.

 LobePro wear plates are reversible; if showing signs of scoring, gouging or similar wear, the wear plate may be flipped rather than replaced. If the wear plate has lost much of its thickness due to abrasion, replacing the wear plate may be necessary to regain flow.

 Seal integrity can be verified by conducting a pressure test on the seal quench chamber and gear housing. This process is detailed in Section 10.5.

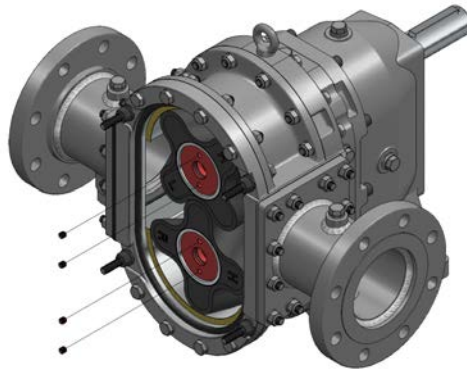

Reference Part No.:

S-frame: 23, 80

M-, L-frame: 36, 57

Reference Tool Sizes:

S-frame: 13 mm wrench/socket

M-, L-frame: 17 mm wrench/socket

Fig. 10.1.4 "Shaft hole" wear plate removal

1. Unfasten and remove the two (2) wear plate mounting bolts, bracing the cover as necessary. Discard these bolts; each wear plate kit includes a new set of mounting bolts.
2. If the wear plate does not immediately come loose, use the back handle of the mallet, or a similar tool, to knock the wear plate and break any vacuum which may have developed behind it. If the process fluid has a tendency to harden/solidify, it may be necessary to trace the exterior edge of the wear plate and break away any hardened material.
3. Remove the wear plate. If the wear plate is in good condition, it may be re-used or flipped for continued use.

Note: If the housing segments have been repositioned (Section 10.6), the wear plate may be locked into position. If unable to remove the wear plate, ensure that the housing segments are in their base (Pin 1) position.

10.1.5 Removing the Mechanical Seal Assemblies

Ensure that all oil has been fully drained and that the "shaft hole" wear plate has been removed before attempting to remove the mechanical seals. Removal of the seals requires the use of two set screws on each holder, which are inaccessible unless the wear plate has been removed.

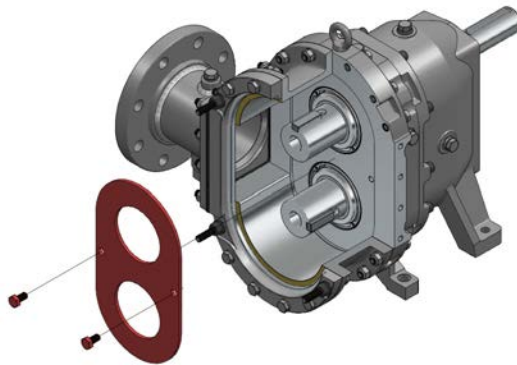

Reference Part No.:

S-frame: 50, 51
M-, L-frame: 31, 32

Reference Tool:

O-ring pick

Fig. 10.1.5.1 Removal of the seal washer and shaft O-ring

- Using an O-ring pick or similar instrument, remove the seal washer and shaft O-ring. Removal of the shaft O-rings is optional, but will cause more resistance if not removed. Each shaft will have two O-rings, though it is often difficult to remove the second O-ring; it can be removed after the seals have been removed.
Discard the shaft O-rings; these should be replaced each time they are removed. The seal washer may be re-used if in adequate condition and free from burrs or sharp edges.

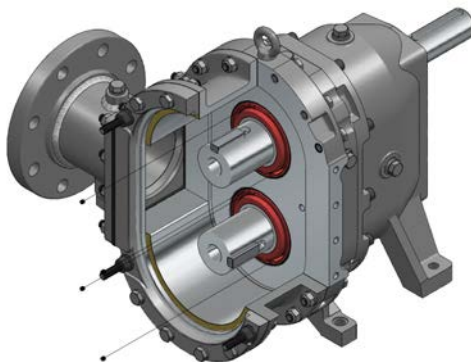

Reference Part No.:

S-frame: 42, 48
M-, L-frame: 24, 25

Reference Tool Sizes:

S-frame: 1.5 mm hex key
M-frame: 2.5 mm hex key
L-frame: 3 mm hex key

Fig. 10.1.5.2 Removal of seal carrier set screws

- Using a hex key, remove the two (2) set screws from the stationary seal carrier of each seal. Set these aside to reinstall in each seal carrier after removal of the seal assemblies.

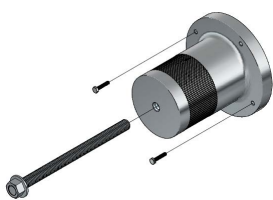

Fasteners:
Two M3 x .5 x 16
M12 x 1.75 Stud

S-frame



Fasteners:
Three M10 x 1.5 x 80
M-frame: Two M5 x .8 x 25
Two M5 x .8 hex nuts
L-, Lh-frame: Two M6 x 1 x 25
Two M6 x 1 hex nuts

M, L-, Lh-frame

Fig. 10.1.5.3 Seal removal tools

3. Prepare the seal removal tools and collect all fasteners per Fig. 10.1.5.3. For M-, L-, and Lh-frame tools, insert the smaller bolts into the two (2) interior clearance holes. The bolt head should be against the flat, un-stepped surface. Install the hex nuts on the opposite side of the seal puller tool and fasten until the bolt is only slightly loose in the assembly. The intent is to secure the bolt to the tool ring while ensuring sufficient thread engagement with the seal holder.

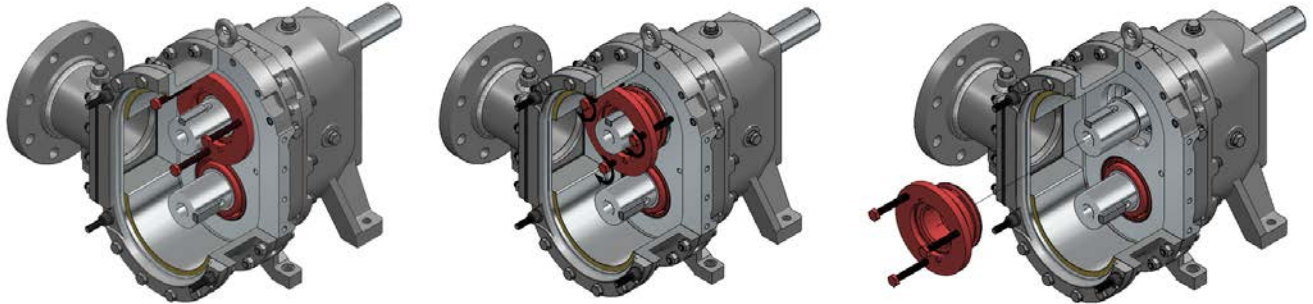

Fig. 10.1.5.4 Installation of the seal puller tool and removal of the seal assembly (M-, L-, and Lh-frame only)

4. Insert the seal puller assembly onto the shaft. Fasten the smaller bolts into the threaded holes of the stationary seal holder. Ensure that the bolts are sufficiently tight by pulling on the assembly.
5. Tighten the larger outside bolts in an alternating pattern to slowly pull the seal from the quench chamber. Once the middle O-ring is exposed, the seal assembly should slide out with ease. For assemblies with coatings on the quench chamber face, take care to ensure the jacking bolts do not mar or damage the coating.

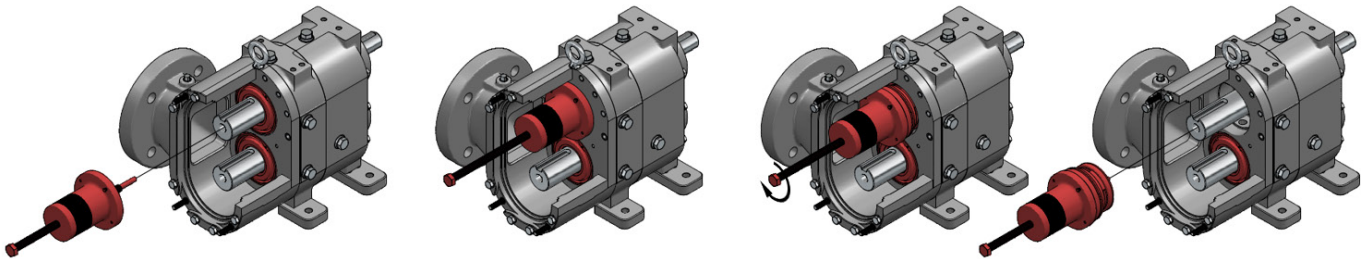



Fig. 10.1.5.5 S-frame seal assembly removal

-  For the S-frame, insert the threaded stud from the Lobe Puller tool into the hub of the Seal Align tool. This will be used as a jacking bolt to remove the seal assembly, as shown in Fig. 10.1.5.5. As you turn the stud clockwise (in a tightening motion), the seal should be slowly pulled from the bore.

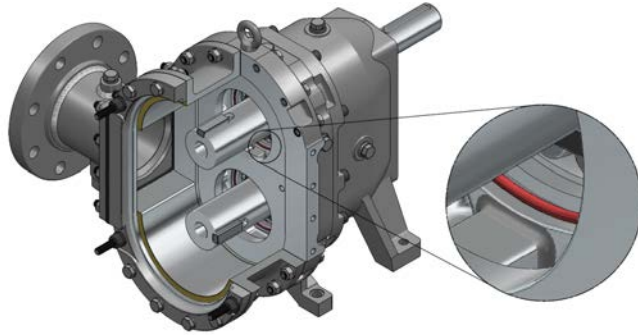

Fig. 10.1.5.6 Removal of the secondary O-ring from the seal bore

6. Remove the secondary O-ring from the seat of the seal bore, as shown in Fig. 10.1.5.6. Ensure that the seal bore and surrounding surfaces are thoroughly cleaned before installing the new/rebuilt seal assembly.



Reference Part No.:

S-frame: 42, 48

M-, L-frame: 24, 25

Reference Tool Sizes:

S-frame: 1.5 mm hex key

M-frame: 2.5 mm hex key

L-frame: 3.0 mm hex key

Fig. 10.1.5.7 Reinstallation of the seal holder set screws

7. Ensure that the seal holder set screws and threads are clean and free from contamination or debris. Reinstall the set screws removed in Step 2 to ensure that they are not lost or forgotten. Apply anti-seize to the screw threads to ensure that the set screws may be removed with ease in the future.
8. Inspect the seal assembly to verify if any components may be salvaged. Salvageable components may include the seal holders, lip seal, lip seal retaining ring, and the mechanical seal faces and their O-rings. The secondary O-rings must be replaced each time the seal is removed. Face seal O-rings must be replaced each time the mechanical seal faces are replaced; or as necessary upon inspection.

10.2 Pump Reassembly

10.2.1 Installing the Mechanical Seal Assemblies

The LARS seal is a two-part assembly; it is therefore important to ensure proper care is taken in handling and installing these seals to avoid contamination or other issues. Follow all recommended instructions and procedures in the installation of the seals to achieve the expected reliability, efficiency, and performance of the rotary lobe pump for the given application. Failure to follow these instructions and maintain cleanliness during installation may result in premature failure of the seals, resulting in unwanted pump or system downtime or failure.

 If using a rebuilt seal assembly, ensure that all surfaces are free from dirt, debris, and other contamination, and that all faces are free from damage.

1. Ensure that the seal bores and shafts are thoroughly cleaned and dried, and free from dirt, debris, and that there are no signs of damage to the components.

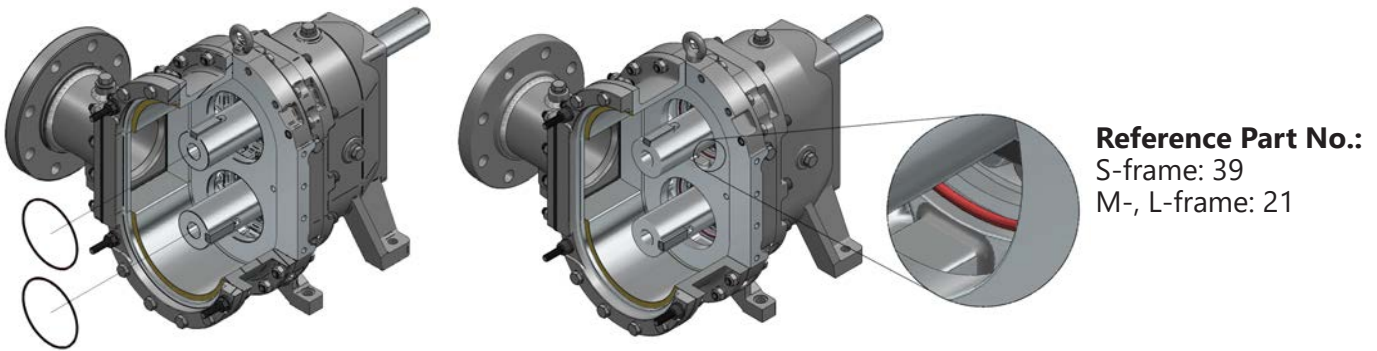

10.2.1.1 Installation of the secondary O-ring in the base of the seal bore

2. Apply a generous amount of grease to one secondary O-ring, and install it in the seal bore such that the O-ring is fully seated at the base of the seal bore. In most cases, the maintenance will be performed in the upright position shown above. As a result, it is possible for this O-ring to unseat before the seal is installed. If the O-ring is not properly positioned, the pump may see communication between the seal quench chamber and gear housing. This grease helps to ensure that the O-ring remains in place during the assembly process.



Fig. 10.2.1.2 Installation of external secondary O-rings

3. Apply grease or oil to the next secondary (exterior) O-ring and place it onto the center groove of the pre-assembled seal assembly (Fig. 10.2.1.2).
4. Before installing the seal assembly, verify that the mechanical face seals are clean and properly lubricated.
5. Ensure that the interior of the seal assembly is free from dirt and contamination. Apply a thin film of grease or anti-seize to the interior bores and shafts.

- Verify that the secondary O-ring is properly positioned in the seal bore, as shown in Fig. 10.2.1.1. With your finger, trace the profile of the seal bore to ensure that the O-ring is properly positioned.

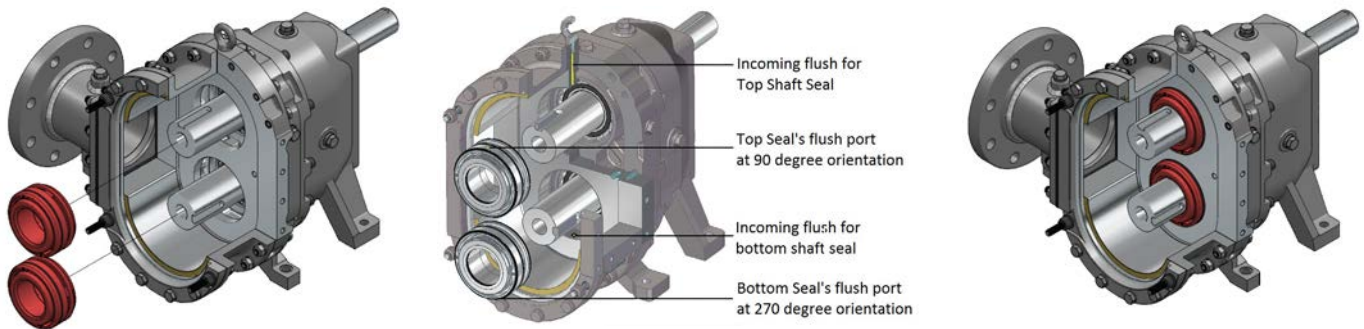

Fig. 10.2.1.3 Installation of the mechanical seal assemblies

- Align the seal assembly with the shaft and push the assembly gently along the shaft. It is typically the case that the seal will “catch” at the location of the middle O-ring such that it is difficult to complete installation by hand. If necessary, use the Seal Aligner tool included in the LobePro Toolbox to complete installation. The Face Seal Pusher tool may also be used for additional leverage.

Note: For seals containing Plan 32 Seal Flush Support:

- For Top Shaft Seal: The Seal’s Flush Port Slot shall be oriented 90 degree towards the top.
- For Bottom Shaft Seal: The Seal’s Flush Port Slot shall be oriented 270 degree towards the bottom.

Note: This tool is specifically designed to press the assembly without exhibiting excessive force on the mechanical seal faces which may risk damage.

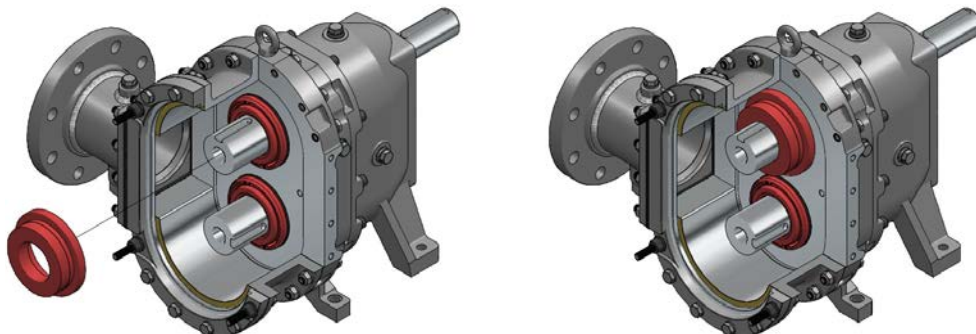

Fig. 10.2.1.4 Use of the Seal Alignment tool to fully position the seal assemblies



Fig. 10.2.1.5 Reference seal installation tools by pump frame

The seal assembly is fully positioned when the stationary seal holder sits flush with the surface of the quench chamber. If the seal assembly does not sit flush, this may indicate that the secondary O-ring in the base of the bore is not properly seated. Remove the seal assembly and verify that the O-ring is installed properly and free from damage.

As shown in Fig. 10.2.1.5, both the M- and L-frame utilize a Seal Alignment tool (left) and Face Seal Pusher tool (right) for seal installation. Due to its smaller size, the S-frame uses a single tool with a threaded stud to aid in seal installation. This stud will fasten into the shaft and slowly press the seal into position as the stud is further tightened.

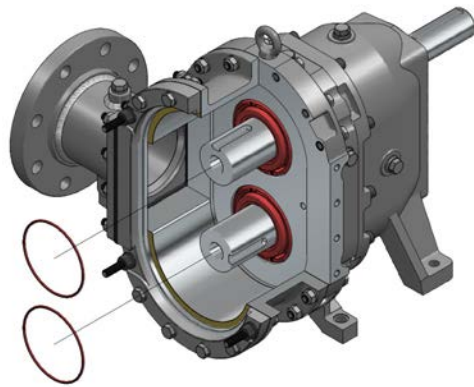

Reference Part No.:

S-frame: 49
M-, L-frame: 21

Fig. 10.2.1.6 Installation of final exterior secondary O-ring

8. Install the remaining secondary O-ring into the groove between the seal holder and quench chamber bore.

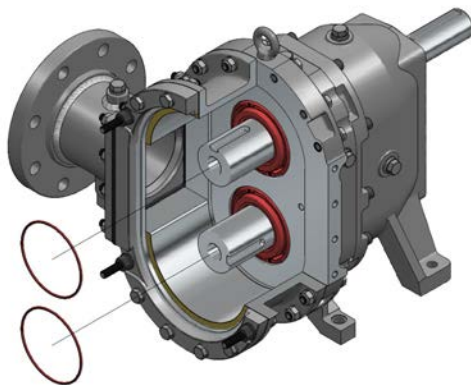

Reference Part No.:

S-frame: 23, 80
M-, L-frame: 36, 57

Reference Tool Sizes:

S-frame: 13 mm wrench/socket
M-, L-frame: 17 mm wrench/socket

Fig. 10.2.1.7 "Shaft hole" wear plate installation

9. Before installing the shaft O-rings and washers, reinstall the quench chamber ("shaft hole") wear plate. Use only stainless steel (or duplex stainless steel, depending on the application) bolts to install the wear plate. Apply anti-seize or a thread locker (such as Loctite 243) to the bolts prior to installation. Torque the mounting bolts manually; do not use an impact wrench.

Table. 10.1 Wear plate mounting bolt torque specifications

Pump Frame	Recommended Torque	
	Dry	Wet
S-frame	10 ft-lb (13.6 N-m)	8 ft-lb (10.9 N-m)
M-, L-, Lh-frame	30 ft-lb (40.7 N-m)	25 ft-lb (33.9 N-m)

The wear plate provides the initial seal compression, to ensure that the seals do not separate when lobes are removed for maintenance. If the shaft O-rings are installed before the wear plate is in place, movement of the rotating seal carrier may unseat the O-rings and compromise their sealing ability.

Note: For LARS Tabbed seal, use tabbed seal alignment tool (Tool.SealAlignM.LK3.S.BN, Tool.SealAlignL.LK3.S.BN) to properly align the keyway prior to shaft oring installation.

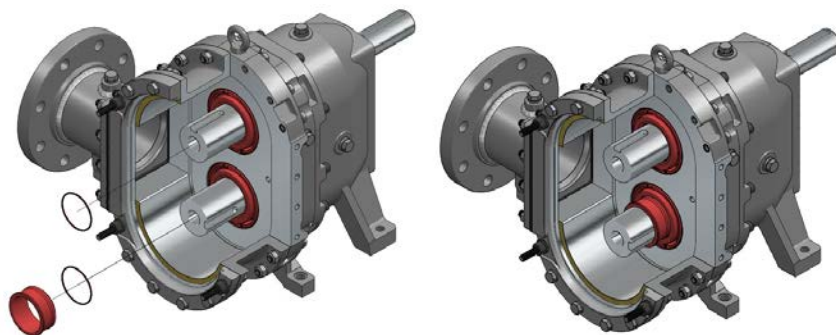

Reference Part No.:

Reference Part No.:

S-frame: 50

M-, L-frame: 31

Reference Tool Sizes:

S-frame: RaceSIR

M-frame: SpacMC.NW

L-frame: SpacLW.NW

Fig. 10.2.1.8 Installation of the shaft O-rings

10. Apply a small amount of grease or oil to the shaft O-ring and gently slide the O-ring evenly along the shaft until it reaches the seal holder. Take care to not prematurely stretch the O-ring or cut the O-ring along the shaft keyway. Use the shaft O-ring installation tool to fully seat the O-ring inside the interior lip of the seal assembly.

To avoid pinching of the O-ring, place the seal washer between the installation tool and the O-ring. Once the O-ring has started to enter the seal bore, you can remove the washer and use the installation tool to fully position the shaft O-ring. Applying a slow, twisting motion with the installation tool will also help ensure that the O-ring is not pinched or otherwise damaged during installation.

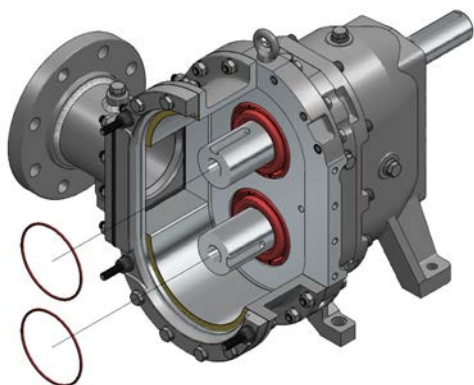

Reference Part No.:

S-frame: 50, 51

M-, L-frame: 31, 32

Fig. 10.2.1.9 Installation of the second shaft O-ring and seal washer

11. Repeat Step 9 to install the second and third (if included) shaft O-ring and seal washer. After installation, the O-ring may protrude slightly out from the seal bore; ensure that the seal washer sits evenly on the seal. If the washer is crooked, the O-ring may not be fully positioned.

Do not rotate the shafts until the lobes have been installed, as this may cause the shaft O-rings to unseat, increasing the risk of seal failure.

10.2.2 Installing the Lobes

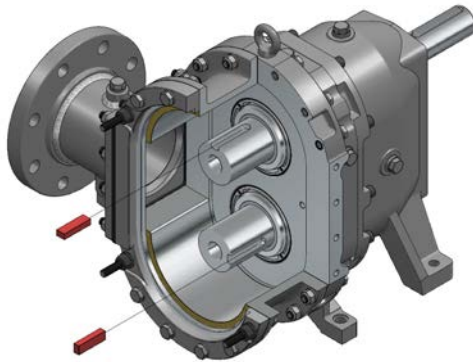

Reference Part No.:

S-frame: 36
M-, L-frame: 20

Fig. 10.2.2.1 Installation of lobe keys

1. Inspect each key for damage or burrs; break any sharp edges or burrs, or replace the key as necessary. Install the lobe keys in each shaft keyway. Ensure that the end of the key is flush with the end of the shaft.
2. If not already done, apply a thin film of grease or anti-seize to the shaft surface.

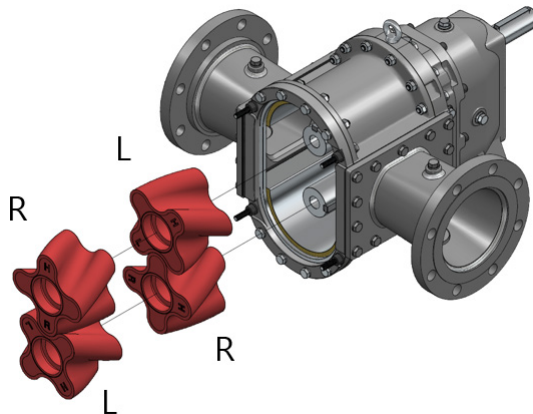

Reference Part No.:

S-frame: 52, 53
M-, L-frame: 37, 38

Fig. 10.2.2.2 Installation of lobes

3. Install the lobes, ensuring that the recessed bore faces out from the pump. Each helical lobe is designated with an "L" or "R" representing the direction of the helix. Lobes must be installed as opposite pairs to ensure proper rotation.

Set the first lobe on the bottom shaft and press the lobe until it just catches the shaft key. If the lobe is pressed too far, it will be difficult to install the mating lobe. Then set the opposite lobe on the top shaft and press the lobe until it also catches the shaft key. Once both lobes are aligned to the key, fully position the lobes so that they reach the seal assembly and wear plate. Depending on the condition of the lobe bore and shaft, it may be necessary to use a rubber mallet to drive the lobes into position.

For LobePro M- and L-frame pumps with tabbed seals, align the tabs and slots together.



Fig. 10.2.2.2A Installation of lobes

Note: Select pump frames use multiple sets of lobes. In order to maintain a continuous sealing surface for the sake of pump efficiency, lobes must be installed in alternating sets, as shown in Fig. 10.2.2.2 and Fig 10.2.2.3.

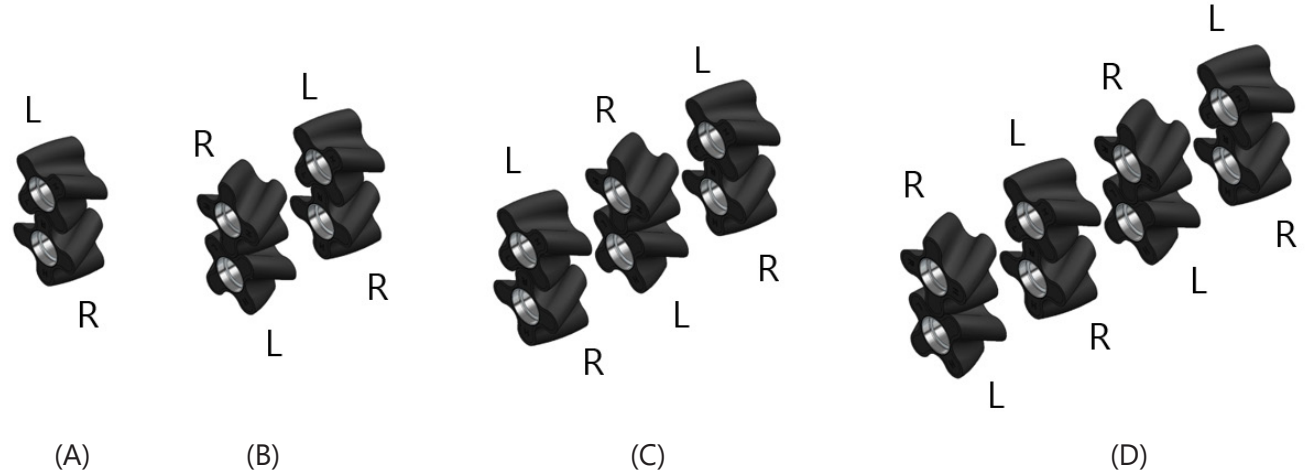

Fig. 10.2.2.3 Reference lobe arrangements

Reference Frame Assemblies

- A) S8, S16, M34, M50, M68, L133*
- B) S16**, M68**, M100, L266*
- C) L399*
- D) L531*

* Included high pressure frame variants

** Assembly may use stacked lobes, but this is not the standard configuration

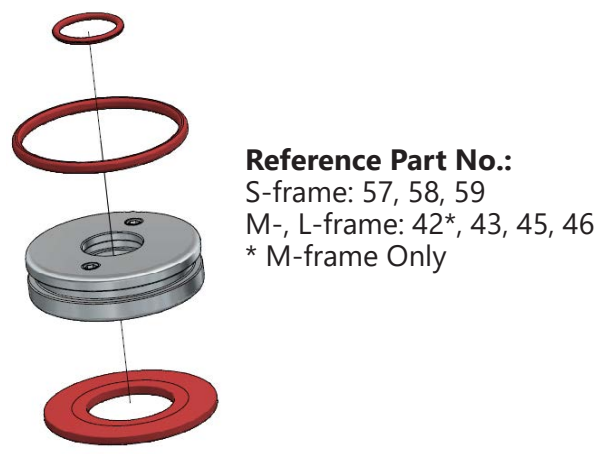

Reference Part No.:
 S-frame: 57, 58, 59
 M-, L-frame: 42*, 43, 45, 46
 * M-frame Only

Fig. 10.2.2.4 Reassembly of the pressure disc

4. If not already completed, reassembly the pressure disc by installing the Belleville spring washer (S- and M-frame Only) and the exterior and interior O-rings. The spring washer will press onto a step on the backside of the pressure disc. Ensure that the concave side of the spring washer faces away from the pressure disc. It may be slightly loose after assembly, but this will not affect performance. A ball peen hammer may be used to lock the washer into place if necessary.

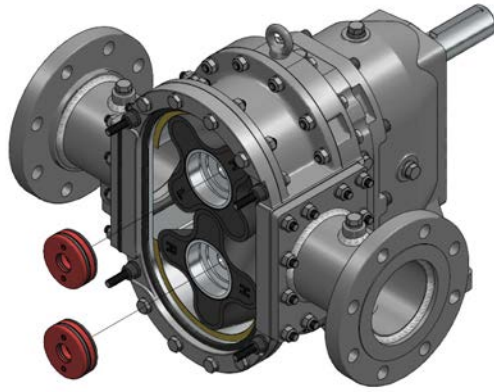

Reference Part No.:
 S-frame: 56, 57, 58, 59
 M-, L-frame: 42, 43, 45, 46

Fig. 10.2.2.5 Installation of the pressure disc assemblies

5. Ensure that the interior of the lobe bores are free from dirt and other contaminants.
6. Apply 2 or 3 drops of the proper Loctite per Table 10.2 to the bottom of the shaft hole into which the strain bolt is threaded. See Loctite video for additional details - <https://youtu.be/MCMJt5qMR50>.
7. Apply a thin film of grease or oil to the exterior of the pressure disc assembly and insert the assembly into the lobe bore. Ensure that the pressure disc is parallel with the lobe surface when installed. For L-frame assemblies, ensure that the protrusion on the back of the pressure disc aligns with the lobe keyway.

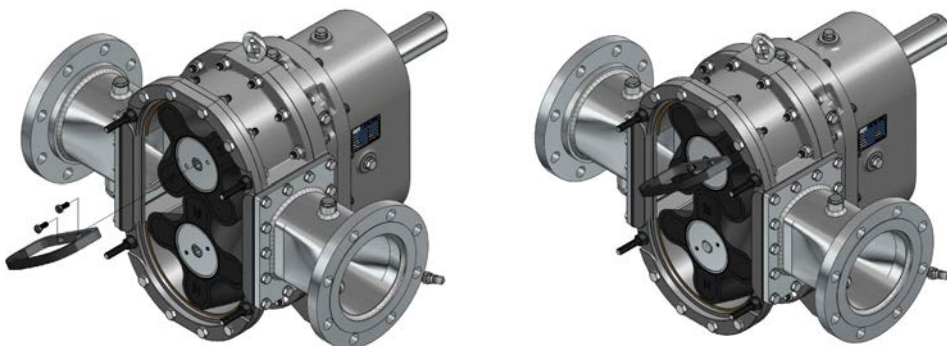

Reference Tool Sizes:
 L-frame: 13 mm wrench

Fig. 10.2.2.6 Installation of pressure disc removal / alignment tool

To ensure that the pressure disc protrusion aligns with the lobe keyway, the removal tool, Tool. PDRemover.LM.S, may be used to rotate the pressure disc. The pressure disc shall sit flush with the face of the lobe when correctly positioned.

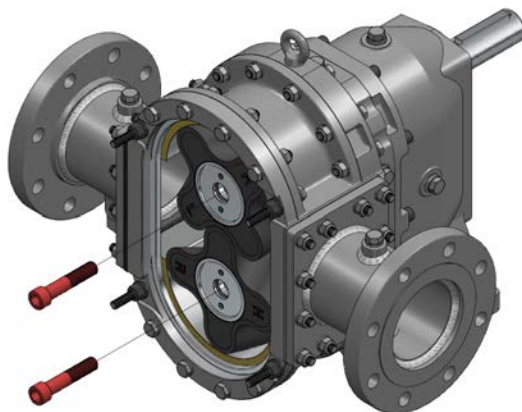

Reference Part No.:
 S-frame: 60
 M-, L-frame: 47

Reference Tool Sizes:
 S-frame: 8 mm
 M-, L-frame: 14 mm

Fig. 10.2.2.7 Installation of the strain bolts

8. Apply proper Loctite per Table 10.2 to 2 or 3 threads of each strain bolt and fasten into the center of the pressure disc. Tighten by hand until it cannot be tightened further. Tighten the strain bolts as specified in Table 10.2.

Table 10.2 Recommended tightening torques for strain bolts with Loctite applied as directed above.

Pump Frame	Recommended Torque		
	S-Series (Steel, Geomet-coated)	C-Series (Stainless steel)	D-Series (Duplex stainless steel)
S-frame	40 ft-lb (54.2 N-m)	55 ft-lb (74.6 N-m)	50 ft-lb (67.8 N-m)
M-, L-frame	140 ft-lb (189.8 N-m)	160 ft-lb (216.9 N-m)	170 ft-lb (230.5 N-m)
Loctite Type	243	263	243

As the strain bolt is torqued, it will likely exceed the starting torque of the shaft, causing the shaft to rotate. To counteract this rotation, place a rag or other soft, compressible item between the lobe tips to lock the pump.



Use caution when placing items between the lobe tips to ensure that your fingers are not caught by the rotating lobes. Keep hands clear when rotating the shafts.

As shown in Fig. 10.2.2.8, insert a rag between the lobe tips to lock the shafts when tightening the strain bolt. When tightening the bottom strain bolt, place a rag on the left side of the lobes and vice-versa when tightening the top strain bolt. Do NOT rotate the bolts in the counter-clockwise direction to remove the rag or item; instead, rotate the opposite bolt clockwise to reverse the shaft rotation and remove the rag or item.

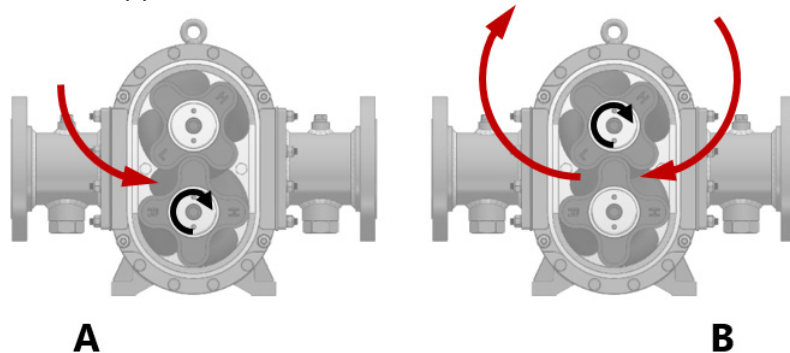

Fig. 10.2.2.8 Reference rag location to prevent rotation when tightening the strain bolts.

10.2.3 Installing the Pump Cover and Cover Wear Plate



Reference Part No.:

S-frame: 27, 80
M-, L-frame: 48, 57

Reference Tool Sizes:

S-frame: 13 mm wrench/socket
M-, L-frame: 17 mm wrench/socket

Fig. 10.3.1.1 “No hole” cover wear plate installation

1. Before reinstalling the cover wear plate, ensure that any ribbing/cavities in the pump cover are clean and free from any residual fluid, dirt, or debris.
2. Place the “no hole” cover wear plate onto the pump cover, as shown in Fig. 10.3.1.1. The wear plate profile and mounting holes should align with the cover.
3. Apply anti-seize or a thread locker (such as Loctite 243) to the threads of each mounting bolt and fasten into the pump cover. Torque the mounting bolts manually in accordance with the specifications in Table 10.1; do not use an impact wrench.

Table. 10.1 Wear plate mounting bolt torque specifications

Pump Frame	Recommended Torque	
	Dry	Wet
S-frame	10 ft-lb (13.6 N-m)	8 ft-lb (10.9 N-m)
M-, L-, Lh-frame	30 ft-lb (40.7 N-m)	25 ft-lb (33.9 N-m)



Reference Part No.:

S-frame: 21
M-, L-frame: 49

Reference Tool Sizes:

S-frame: 13 mm wrench/socket
M-, L-frame: 17 mm wrench/socket

Fig. 10.3.1.3 Pump cover O-ring installation

4. Inspect the cover O-ring for signs of wear or damage; replace as necessary. Apply a small amount of grease or oil to the O-ring and install around the cover wear plate. Ensure that the O-ring is not rolled upon installation.

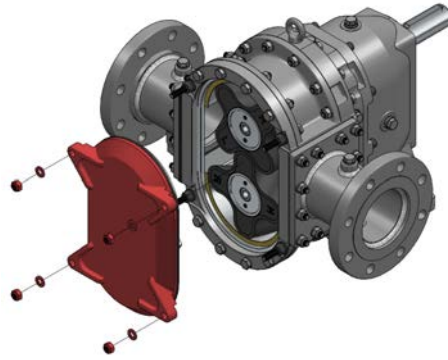

Reference Part No.:

S-frame: 28, 63, 81
 M-, L-frame: 50/51, 63, 65

Reference Tool Sizes:

S-frame: 13 mm wrench/socket
 M-frame: 17 mm wrench/socket
 L-frame: 19 mm wrench/socket

Fig. 10.3.1.1 “No hole” cover wear plate installation

5. Align the pump cover with the four mounting bolts on the pump. Ensure that the cover O-ring is not damaged upon installation. For best results, angle the bottom of the cover inward slightly when installing the cover.
6. Reinstall the flat washers and lock nuts. Tighten the four lock nuts evenly in a start (diagonal) pattern, according to the torque specifications in Table 10.4.

Table 10.4 Pump cover bolts tightening torques

Pump Frame	Recommended Torque	
	Dry	Wet
S-frame	20 ft-lb (27.1 N-m)	16 ft-lb (21.7 N-m)
M-, L-, Lh-frame	35 ft-lb (47.5 N-m)	28 ft-lb (38.0 N-m)

10.3 Lh-frame High Pressure Door Assembly

10.3.1 Removing the High Pressure Door Assembly



Before removing the high pressure door assembly or any components, ensure that all oil chambers have been thoroughly drained.

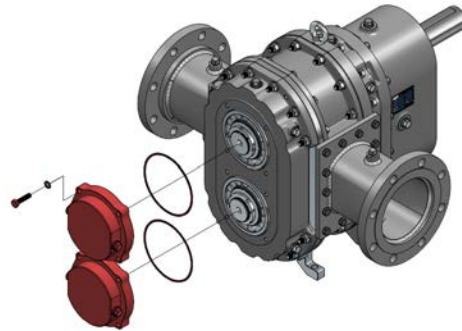

Reference Part No.:
91, 92, 93, 98

Reference Tool Sizes:
17 mm wrench/socket

Fig. 10.3.1.1 "No hole" cover wear plate installation

1. Unfasten the hex head bolts from the bearing cover and remove each cover. The standard pump assembly uses grease inside the bearing covers, which should be replaced each time the cover is removed and reinstalled. If oil has been used instead, use the side drain plug to drain the oil prior to removal.
2. Remove the bearing cover O-ring from the exterior of the bearing. Inspect the O-rings for signs of damage or deformation and replace as necessary.

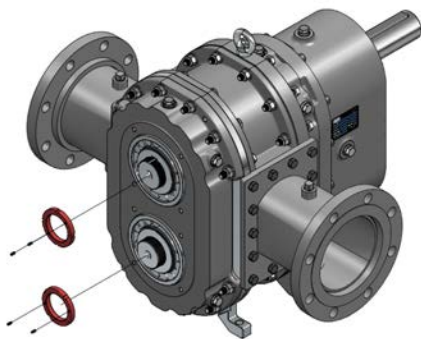

Reference Part No.:
63, 65, 89, 109

Reference Tool Sizes:
Tool.LhDoorSocket (TMFS-12)
2 mm hex key
19 mm socket/wrench

Fig. 10.3.1.2 Removal of the bearing lock nut and set screws

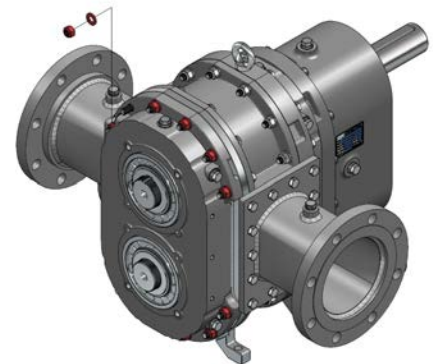
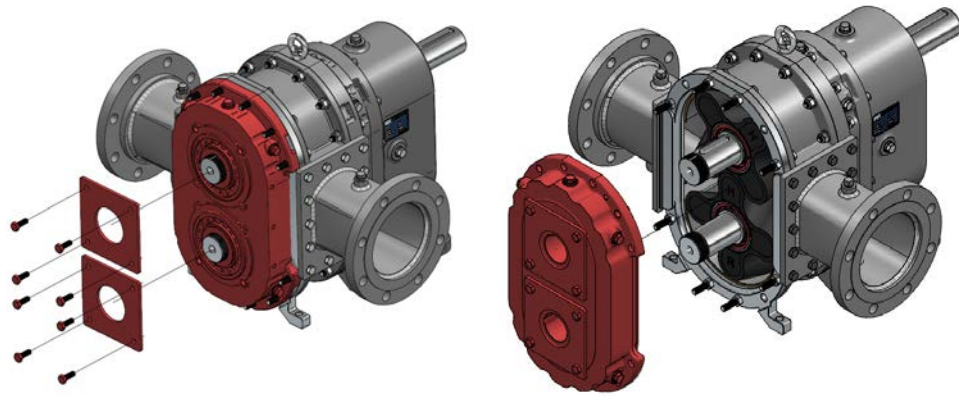

Fig. 10.3.1.3 Removal of the high pressure door lock nuts

3. Unfasten the bearing lock nuts from each shaft. The lock nuts are secured with two set screws each and Loctite 263 high strength thread locker. If experiencing difficulty removing the lock nut, apply localized heat to weaken the thread locker. Inspect each lock nut for signs of damage or defect and discard or set aside for reuse.
4. Unfasten and remove the lock nuts and washers from the high pressure door. Inspect each for signs of damage or deterioration and replace as necessary.



10.3.1.4 Removal of the high pressure door assembly

5. Install the bearing retainer plates (included in the LobePro Lh-frame Tool Box) to prevent rotation of the shaft sleeve. The high pressure door assembly can now be removed. The two notches on each side of the door may be used to back the door off of the spring pins and shafts. The door will need to be moved linearly to ensure there is no damage to the shaft threads. There are two threads on the flanged face which will accept an M12 x 1.75 bolt as a jacking bolt to remove the assembly. The door assembly weighs approximately 130 lbs and may require an overhead lift or multiple individuals to remove.

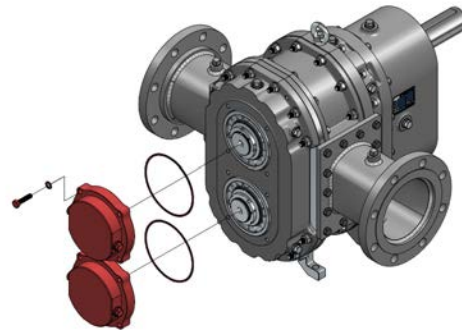

Reference Part No.:
79, 80

Fig. 10.3.1.5 Removal of the lobe spacer and shaft O-ring

6. Remove the lobe spacers if these do not come out with the door assembly. Each spacer includes two M4 x 0.7 threaded holes to aid in removal.
7. Using an O-ring pick, remove the O-ring from each shaft and lobe spacer and discard; these must be replaced each time the high pressure door is removed for maintenance.

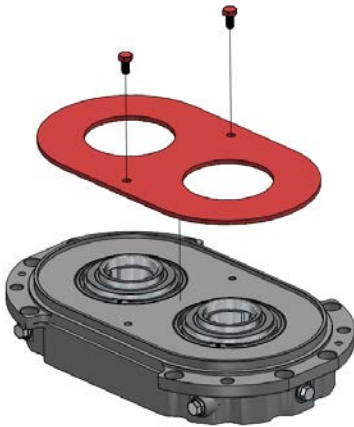

Fig. 10.3.1.6 Removal of the "shaft hole" wear plate

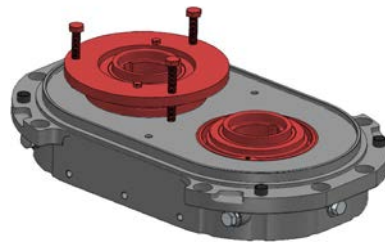

Fig. 10.3.1.7 Removal of the mechanical seal assembly

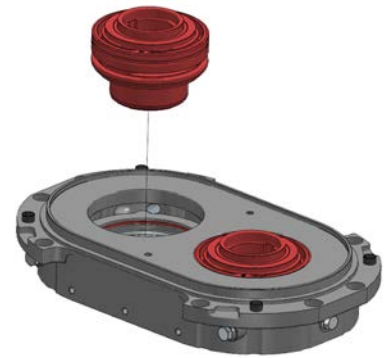

Fig. 10.3.1.8 Shaft sleeve and bearing race are removed with the seal assembly

8. As shown in Section 10.1.4, remove the "shaft hole" wear plate and mounting bolts. If the wear plate is in good condition, it may be flipped and reused. If the wear plate exhibits considerable wear such that its thickness is reduced, it is recommended to be replaced.

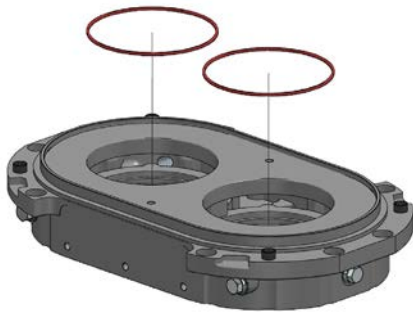
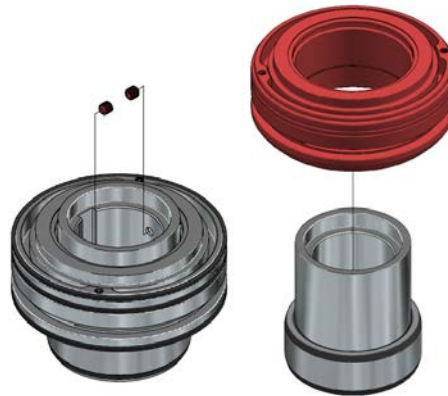

Fig. 10.3.1.9 Removal of the seal bore O-ring



Reference Tool Sizes:
4 mm hex key

Fig. 10.3.1.10 Removal of the shaft sleeve set screws and seal assembly

9. As shown in Section 10.1.5, use the seal removal tool to pull each seal from the bores of the high pressure door. The shaft sleeve is positively engaged with the seal assembly by two internal set screws, and will therefore be removed as a single assembly.
10. Remove and discard the O-ring in the base of each seal bore.
11. Loosen and remove the shaft sleeve set screws and remove the mechanical seal assemblies. These seals can be discarded or rebuilt (Section 10.4) as appropriate.
12. Once the shaft sleeve and seal assemblies have been removed, the roller bearings will be accessible to clean out the old grease. Use a clean, lint-free rag and a hydrocarbon solvent as necessary to clean the bearing rollers.

10.3.2 Installing the High Pressure Door Assembly



If using a rebuilt seal assembly, ensure that all surfaces are free from dirt, debris, and other contamination, and that all faces are free from damage.

1. Ensure that the seal bores, bearing races, and shaft sleeves thoroughly cleaned and dried, and free from dirt, debris, and that there are no signs of damage to the components. Replace the shaft sleeve as necessary.
2. Install the middle secondary O-ring onto the seal assembly.



Reference Part No.:
21 – 32, 85, 87

Reference Tool Sizes:
4 mm hex key



Fig. 10.3.2.1 Installation of the mechanical seals on the shaft sleeve assembly

Fig. 10.3.2.2 Installation of the shaft sleeve set screws

3. Apply a thin film of grease or anti-seize to the interior seal bores and the exterior of the shaft sleeve. Set the seal assembly onto the sleeve until the rotating seal holder touches the bearing race.
4. Install the shaft sleeve set screws and tighten each until they are engaged in the rotating seal holder.
5. Apply a small amount of grease or oil to the shaft O-ring and gently slide the O-ring evenly along the shaft sleeve until it reaches the seal holder. Take care to not prematurely stretch the O-ring during this process. Use the shaft O-ring installation tool to fully seat the O-ring inside the interior lip of the seal assembly.

To avoid pinching of the O-ring, place the seal washer between the installation tool and the O-ring. Once the O-ring has started to enter the seal bore, you can remove the washer and use the installation tool to fully position the shaft O-ring. Applying a slow, twisting motion with the installation tool will also help ensure that the O-ring is not pinched or otherwise damaged during installation.

6. Repeat Step 3 to install the second shaft O-ring and seal washer. After installation, the O-ring may protrude slightly out from the seal bore; ensure that the seal washer sits evenly on the seal. If the washer is crooked, the O-ring may not be fully positioned. It is recommended to use a small amount of lithium grease on the washer, to ensure that it does not fall off when installing the door.



Reference Part No.:
31, 45, 80, 81

Fig. 10.3.2.3 Installation of the lobe spacer O-rings

7. Install the internal and external O-rings of the lobe spacer. Ensure that the O-rings are not rolled after installation. If removed during disassembly, ensure that the spacer set screws are reinstalled.

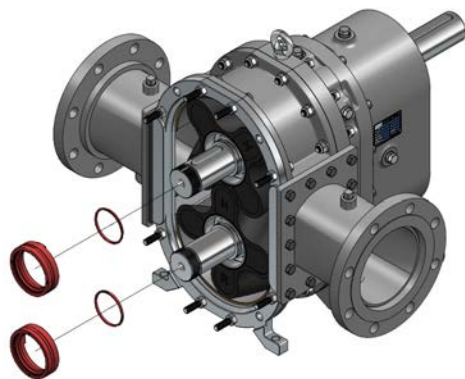

Reference Part No.:
31, 45, 80, 81

Fig. 10.3.2.4 Installation of the lobe spacer

8. Press the lobe spacer into the lobe bore, ensuring that the spacer key aligns with the lobe keyway. When aligned, the spacer shall sit flush in the lobe bore.

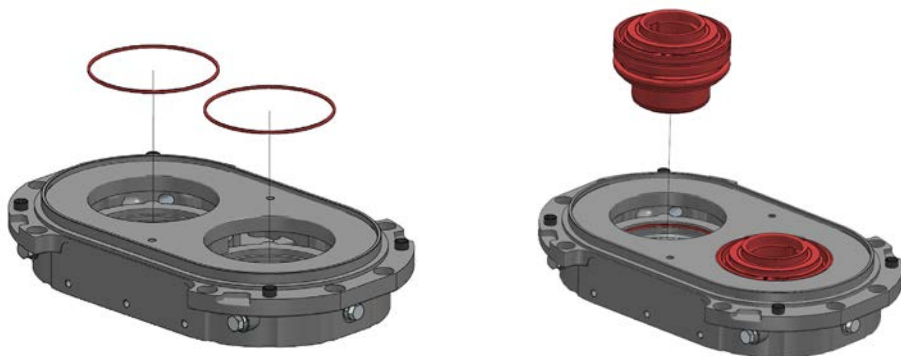

Reference Part No.:
21, 31, 45, 80, 81

Fig. 10.3.2.5 Installation of the quench chamber O-ring and seal assembly

9. Install the secondary O-rings into the middle groove of the seal assembly.
10. Apply a generous amount of grease to the bearing rollers and ensure even distribution.
11. As shown in Section 10.2.1, install the seal O-ring in the seat of the quench chamber bores and gently press the seal assembly from Step 6 into each bore.

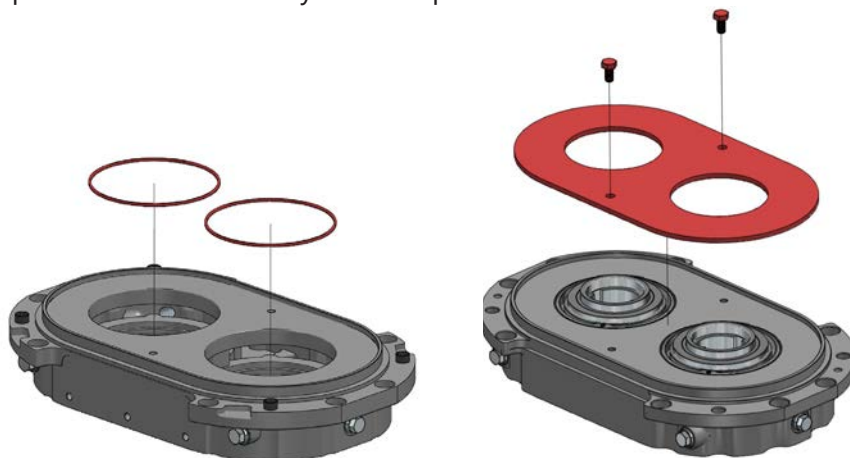

Reference Part No.:
21, 36, 68

Fig. 10.3.2.6 Installation of the final secondary O-ring and wear plate

12. Install the remaining secondary O-ring into the groove between the stationary seal holder and the quench chamber bore as shown in Fig. 10.3.2.6.

13. Set the "shaft hole" wear plate on the quench chamber, aligning the two holes with easy seal assembly. Use only stainless steel (or duplex stainless steel, depending on the application) bolts to install the wear plate. Apply anti-seize or a thread locker (such as Loctite 243) to the bolts prior to installation. Torque the mounting bolts manually; do not use an impact wrench.

Table. 10.1 Wear plate mounting bolt torque specifications

Pump Frame	Recommended Torque	
	Dry	Wet
Lh-frame	30 ft-lb (40.7 N-m)	25 ft-lb (33.9 N-m)

14. Install the shaft O-rings and seal washer, as shown in Fig. 10.1.5.8.

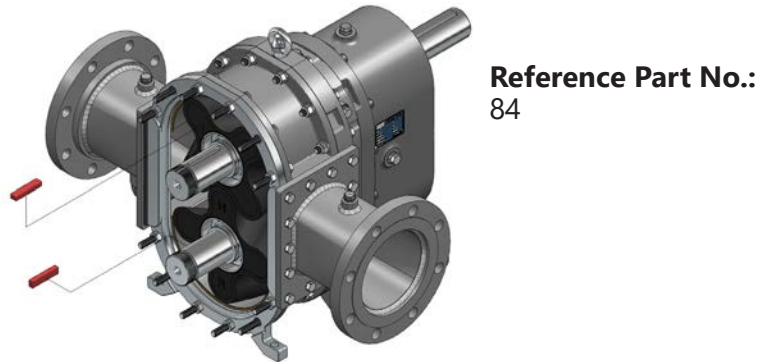

Fig. 10.3.2.7 Installation of the shaft sleeve keys

15. If removed during disassembly, ensure that the shaft sleeve keys are reinstalled. Each key will have a rounded edge, which will face outward from the pump. Ensure that the shafts and keys are free from dirt, debris, and damage. Replace the shaft sleeve keys as necessary. Contact LobePro if there is evident damage to the shafts.

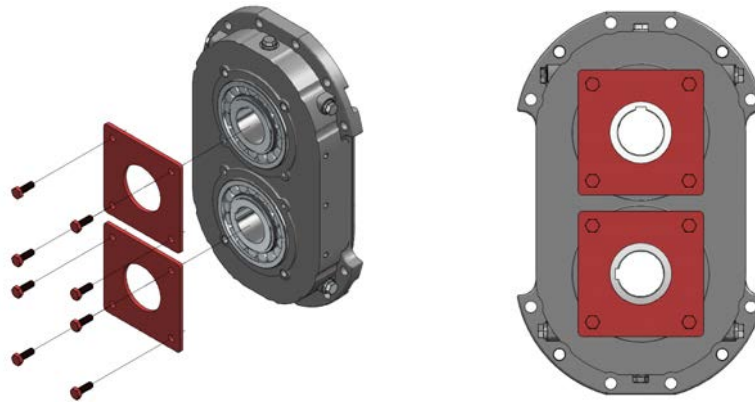

Fig. 10.3.2.8 Installation of the bearing / sleeve locking plates

16. Install the bearing / sleeve locking plates (included in the LobePro Toolbox). Tighten each plate such that the shaft sleeves and seals cannot rotate during reassembly, but can still adjust to meet the shaft key.

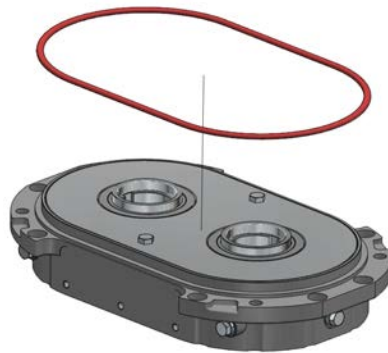
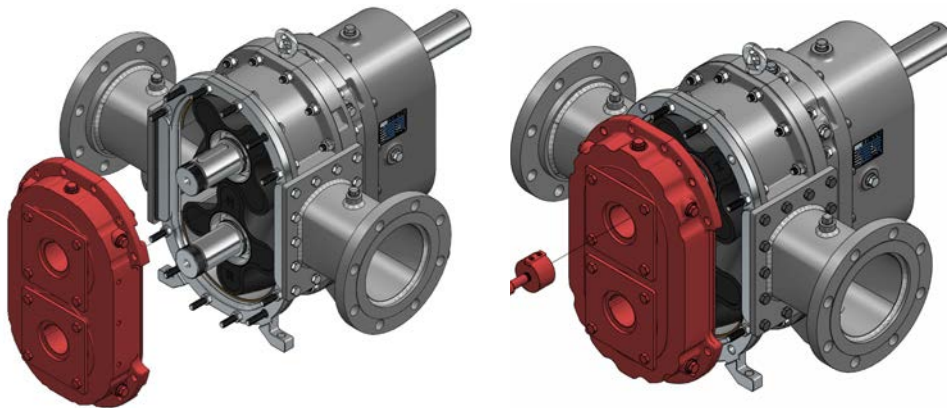

Fig. 10.3.2.9 Installation of the high pressure door O-ring

17. Replace the high pressure door O-ring and verify that the O-ring is not rolled or otherwise damaged during assembly. A thin film of grease may be applied to ensure the O-ring maintains position during installation.
18. Inspect the pump shafts and ensure they are free from dirt and debris, and any burrs or damage. Apply a thin film of grease or oil to each shaft to aid in installation.



Reference Tool Sizes:
Lh-frame: 14 mm

Fig. 10.3.2.10 Installation of the high pressure door assembly

19. Install the high pressure door assembly onto the pump, as shown in Fig. 10.3.2.10. Use the alignment tool, Tool.SleeveAlign.Lh.S, to ensure that the shaft sleeves are properly aligned to the shaft keys. Use the 16 mm socket bolt to rotate the shaft sleeves as necessary, and remove when aligned. Press the door assembly until fully seated.

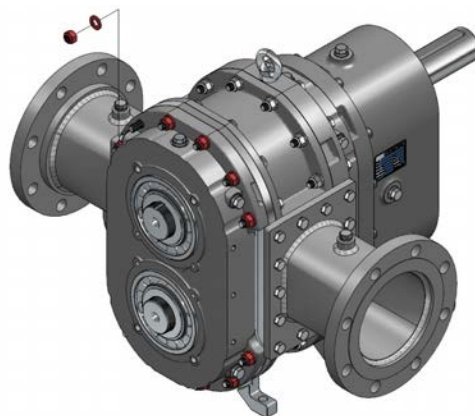

Reference Part No.:
62, 63, 65

Reference Tool Sizes:
19 mm socket/wrench

Fig. 10.3.2.11 Installation of the high pressure door lock nuts

20. Inspect the threads for each bolt. Replace any bolts showing signs of damage.

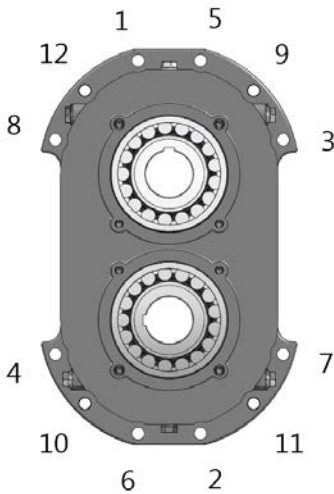
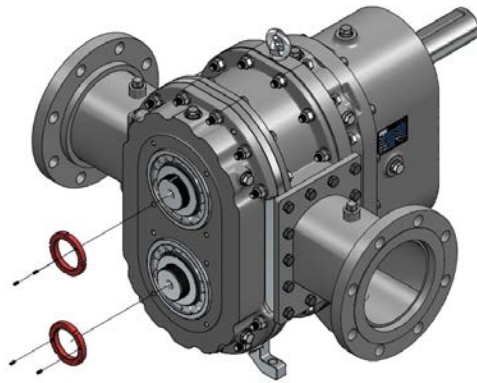

Fig. 10.3.2.12 Bolt tightening/torque pattern for the high pressure door.

Tighten the bolts first to 35 ft-lbs, then 75 ft-lbs.

21. Hand tighten teach bolt, then fasten the lock nuts and flat washers in accordance with the fastening pattern of Fig. 10.3.2.13. Tighten the bolts in two stages; first to 35 ft-lbs, then 75 ft-lbs.



Reference Part No.:

89, 109

Reference Tool Sizes:

Tool.LhDoorSocket (TMFS-12)

2 mm hex key

Fig. 10.3.2.13 Removal of the bearing lock nut and set screws

22. Apply Loctite 263 to the shaft threads.
23. Fasten the bearing lock nut onto each shaft. Tighten by hand until it cannot be tightened further. Using the axial nut socket (Tool.LhDoorSocket), tighten the lock nut to 250 ft-lbs.

This torque is likely to exceed the static shaft torque of the pump and may cause the shafts (and lobes) to rotate. As noted in Fig. 10.2.2.7 of Section 10.2.2, place a rag or similar soft, compressible item between the lobe tips to prevent shaft rotation. Do NOT rotate the nuts in the counter-clockwise direction to remove the rag or item; instead, rotate the opposite nut clockwise to reverse the shaft rotation and remove the rag or item.

24. Apply Loctite 243 to the threads of the lock nut set screws and hand tighten until engaged in the shaft sleeve. Loosen the set screws once, then refasten to ensure engagement.



Allow a minimum of 24 hours for Loctite to fully cure before adding grease to the bearings / covers and returning the pump to service.

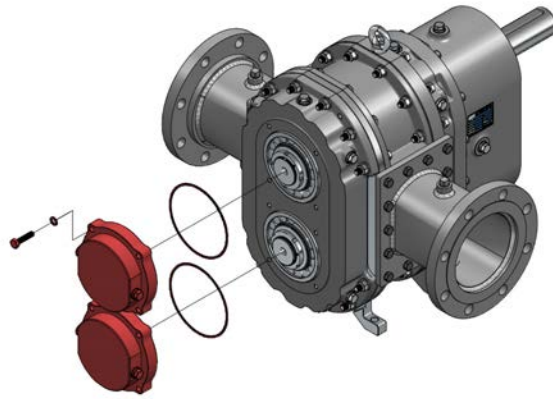

Reference Part No.:
91, 92, 93, 98

Reference Tool Sizes:
17 mm wrench/socket

Fig. 10.3.2.15 Installation of the bearing covers and O-rings

25. Place one cover O-ring around the exterior of each bearing. Ensure that the O-ring is fully positioned against the surface of the high pressure door and is not rolled or otherwise damaged.
26. Ensure that the bearing covers are clean and free from dirt and debris. Install the bearing covers and hand tighten the bolts to minimize exposure to humid air while observing the cure time noted above.
27. After the cure time has been observed, fill the bearing covers with grease (7 fl. oz.) Apply a portion of the grease directly to the bearing rollers and fill the bearing cover with the remainder. Refer to Section 8 for lubrication instructions and recommended brands.
28. Install the bearing covers onto the pump, taking care not to pinch or otherwise damage the O-ring installed in Step 19. Fasten each cover with the four hex head bolts and cap screws, torqued to 35 ft-lbs.
29. Refill the pump quench chambers and gear housing with oil in accordance with the directions in Section 8. Rotate the shafts a minimum of three and a half rotations to ensure the bearings, gears, and seals are thoroughly lubricated.

10.4 Rebuilding the Mechanical Seal Assembly

The (replaceable) sealing components of the mechanical seal assembly consist of the mechanical face seal and O-rings, secondary O-rings, and a lip seal secured by a retaining ring. For the secondary O-rings and the lip seal, operators should follow standard care when installing these parts:

- Ensure that O-rings are not pinched, rolled, or otherwise damaged during assembly and handling
- Before installing a new lip seal, ensure that the bore and retaining ring groove are free from burrs and sharp edges.
- Ensure that the lip seal is pressed evenly into the holder bore and secured in place with the retaining ring.

Beyond these basic components, special care is need when handling and installing new mechanical face seals. The mechanical face seals are considered as a single unit consisting of two halves; these materials are very delicate and brittle, requiring extra care and protection from sharp blows or impacts during handling and installation. Face seals should be regarded as precision elements and the smooth sealing surface should be protected at all times.



Do not drop the face seals. Never place the face seals down such that the smooth sealing surface is in contact with another hard surface.



Do not touch or otherwise handle the face seals with dirty or bare hands. Small dirt particles or other debris may scratch the sealing surface, increasing the risk of premature failure.



Keep face seals in their original packaging until ready for installation. For packages containing multiple sets of face seals, ensure that the package is sealed from dust and dirt after opening.

The majority of premature seal failures are a result of installation errors. Follow all recommended instructions and procedures in the installation of the seals to achieve the expected reliability, efficiency, and performance of the rotary lobe pump for the given application. Failure to follow these instructions and maintain cleanliness during installation may result in premature failure of the seals, resulting in unwanted pump or system downtime or failure. Contact LobePro for any questions or comments before installing these seals.

1. Prior to reinstalling any seal components, ensure that the seal holders have been thoroughly cleaned with a compatible solvent and that they are free from dirt, debris, machining debris and burrs. All holders shall be inspected for cleanliness prior to installing the face seals and O-rings. Pay careful attention to inspect the bottom of the small seal holder for damage. If this area is damaged by a groove, then the small seal holder must be replaced.
2. Remove the face seals from their packaging. Inspect the face seals for signs of damage or other abnormalities. Any scratches, indentation, or other damage to the sealing surface will compromise seal integrity and risk premature seal failure.



Reference Part No.

S-frame: 43, 44

M-, L-, Lh-frame: 26, 27



Fig. 10.4.1 Mechanical face seal (one of two halves), showing smooth sealing surface (exterior ring).

Fig. 10.4.2 Installation of the face seal O-ring

3. Gently wipe the back surface of the face seal (opposite the sealing surface) with a clean, lint-free, cotton rag moistened with denatured alcohol to remove any dirt, debris, or other packaging residue. Repeat this process with the face seal O-ring. For compatibility issues, substitute with deionized water.

- Install the O-ring onto the face seal, ensuring that the O-ring is not rolled, kinked, or otherwise damaged in the process. Position the O-ring on the face seal and slowly press along the circumference of the O-ring until it wraps around the face seal. Inspect for signs of twisting or deformation by inspecting the mold flash, which should run true with the diameter of the O-ring. Twisted O-rings are a common cause of immediate seal failure or reduced service life. The twist, if present, can be eliminated by gently pulling or pushing a section of the O-ring radially away or toward the face seal.

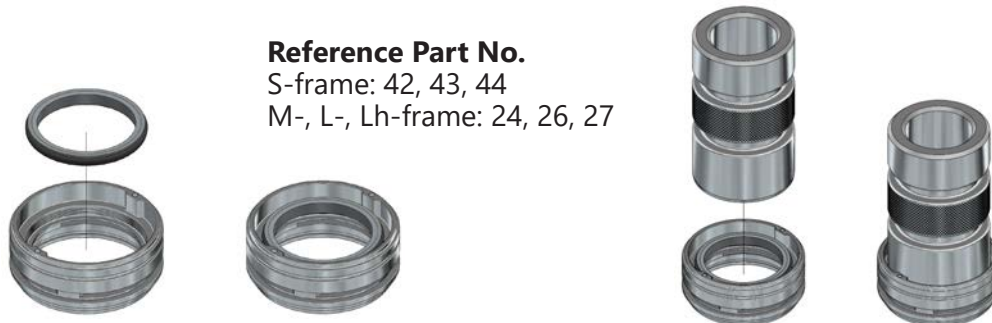

Fig. 10.4.3 Insertion of the face seal and O-ring

Fig. 10.4.4 Installation of the mechanical face seal using the Face Seal Pusher tool.

- Ensure that the seal holder is clean and free from dirt, debris, and damage. Set the face seal and O-ring onto the seal holder, as shown in Fig 10.4.3, ensuring that it is concentric with the seal holder and level.
- Set the Face Seal Pusher tool onto the assembly, taking care not to damage the face seal. This tool is specifically designed to transfer pressure to the O-ring during assembly, protecting the face seal from contact.
- Slowly press the tool into the seal holder as shown in Fig. 10.4.4. The face seal and O-ring should be properly positioned when a sudden “pop” is felt, or the tool is heard to contact the bottom of the seal holder.
- Remove the tool and inspect the position of the face seal and O-ring. When properly installed, the O-ring should be evenly visible around the entirety of the face seal, level with the seal holder. If the face seal appears off center or angled, the O-ring may be crooked inside the holder. Remove the face seal and O-ring and repeat steps 5 to 7, ensuring that the face seal is positioned and level before using the installation tool.
- Repeat this process for the other seal holder, and other seal assemblies. It is recommended that this process is only carried out for one seal assembly at a time, to ensure that the mated seal faces are not mixed up between multiple assemblies.
- Once the face seal and O-ring are properly installed in the primary/rotating and secondary/stationary seal holders, again ensure that the face seals are clean and free from dirt, debris, and damage. Apply a thin film of seal oil to the sealing surface of each face seal; do not apply excessive oil.
- Ensuring that the lip seal and retaining ring have already been installed, reassemble the seal by gently rotating the primary seal holder while inserting the holder into the secondary seal holder assembly. Ensure that the lip seal race passes through the lip seal without rolling or damaging the lip seal. The seal is now ready to be reinstalled with the exterior and shaft O-rings.

10.4.1 When to Replace Mechanical Face Seals

The lapped sealing face of the mechanical face seal is the initial seal contact for a new assembly. As the pump continues to operate and wear increases, this contact point will move inward until approximately two-thirds of the seal width has worn away. After this point, the seal faces should be replaced.

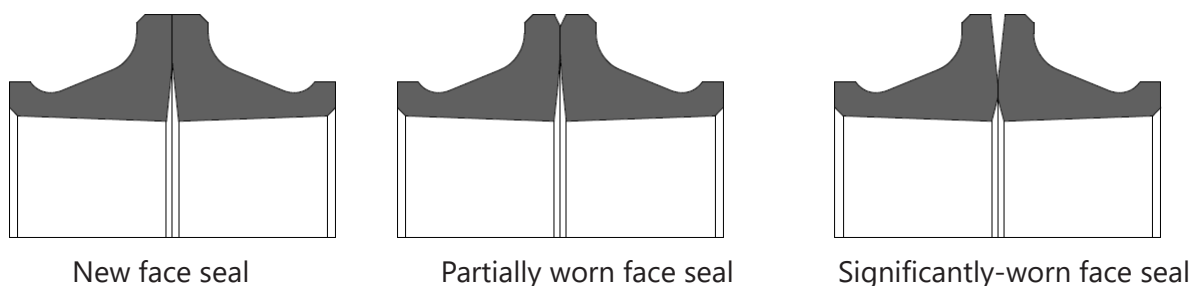

Fig. 10.4.5 Reference images for seal wear and replacement

10.5 Pressure Testing the Mechanical Seals

Prior to returning the pump to service following maintenance or repair, it is important to test the integrity of the seals as installed. It is therefore recommended to test both the seal quench chamber and gear housing with air pressure prior to filling them with oil.

In order to perform this pressure test, install a basic assembly consisting of a minimum of:

- M16 x 1.5 thread adaptor for seal quench chamber and gear housing fill ports
- Pressure gauge, rated to a minimum of 30 psig
- On/off valve or similar
- Connection/nozzle for air

Each chamber may be tested independently, but the most thorough test involves testing the seal quench chamber and gear housing simultaneously, as shown in Fig. 6.1. For this process:

1. Slowly pressurize the seal quench chamber to 20 psig; close the valve.
2. Slowly pressurize the gear housing to 15 psig; close the valve.
3. Verify that each chamber retains pressure for at least 30 minutes. During this process, rotate the drive shaft at least three full revolutions to dynamically test the assembly.
4. If either chamber fails the pressure test, check that all drain and fill plugs and sight glasses are installed and tightened. Inspect the casing, lip seal, and shaft cover for signs of leaks. If any corrections were made, repeat this test.



Fig. 10.5 Reference seal pressure test assembly

There are four possible outcomes for this test:

1. Both chambers retain their original pressure (or within 1 psi): The seals are installed properly and the pump is ready for operation. Refill each chamber with the proper lubricant and reinstall the fill plugs.
2. The seal quench chamber loses pressure, but not the gear housing: There is an error with either the mechanical face seals and their O-rings or the external secondary O-rings. Remove the seal assemblies and verify that the seal faces and O-rings are installed correctly and are free from damage.
3. The gear housing loses pressure, but not the seal quench chamber: This is most commonly caused by damage to the shaft O-rings. Verify that the O-rings are properly installed and free from damage or defect.
4. Pressure equalizes between the seal quench chamber and gear housing: This is most commonly caused by a failure to reinstall the secondary O-ring in the base of the seal bore (Fig. 3.2). Also verify that the lip seal is undamaged and lip seal springs present and undamaged.

10.6 Adjusting the Housing Segments & Lobe Clearances

Note: This section applies only to assemblies with component (“adjustable”) housing segments. The S-frame ProForm series cannot be adjusted for lobe clearances in this manner.

The pump housing segments are designed with an offset in the bolt hole patterns so that the housing segments can be adjusted inward to reduce clearances between the lobe tips and housing segments after the lobes have seen significant wear.



Ensure that all safety instructions in Section 1.0 are observed before attempting any maintenance on the pump.

For the purposes of this procedure and as shown in Fig. 10.6.1, the bolt hole locations are referred to as:

- Pin 1 Location: Closest to the shaft horizontal centerline
- Pin 2 Location: Second closest to the shaft horizontal centerline
- Pin 3 Location: Further from the shaft horizontal centerline

As the slotted roll pin (spring pin) is moved from Pin 1 to Pin 2 and Pin 2 to Pin 3, the housing segments move inward, toward the pump centerline, thereby allowing the user to regain flow efficiency and pressure generation without having to replace the lobes immediately. This adjustment should only be performed when the lobe tip-to-housing clearance exceeds 0.060 in (1.5 mm).

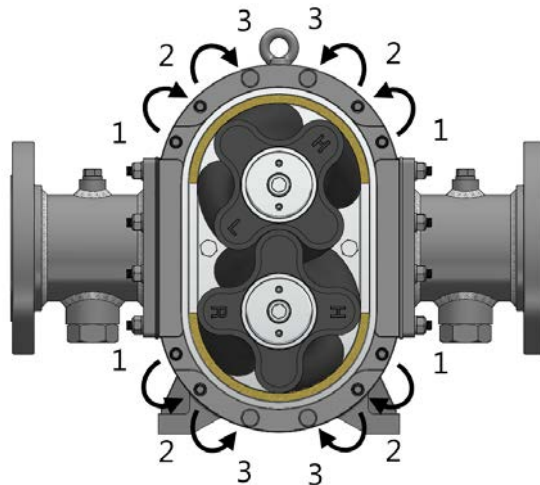
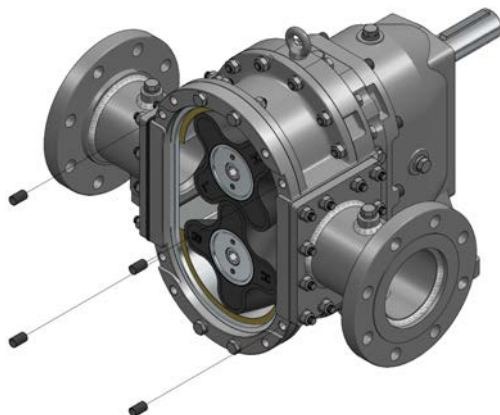

Fig. 10.6.1 Reference pin locations and adjustment pattern

To adjust the housing segments:

1. Loosen and/or remove the transition fittings from the pump.
2. Remove the pump cover and O-ring.



Roll pin diameter:

S-frame: 0.430 in (11 mm)

M-frame: 0.510 in (13 mm)

L- and Lh-frame: 0.630 in (16 mm)

Fig. 10.6.2 Removal of the split roll pins

3. Remove the bolts from the current position of the roll pin (default Pin 1 Location) and the final location. Loosen the other set of bolts. This will be done for the flange ring and quench chamber, for a total of eight (8) roll pins.
 - a. Unless clearances are extreme, it is recommended that the roll pins are moved one position at a time. E.g. 1 to 2 or 2 to 3.
4. Press the roll pins from their original location. Reference hole diameters are given in Fig. 10.6.2. Use caution when removing the roll pin, as the spring-like behavior may cause the roll pin to shoot off in a random direction.

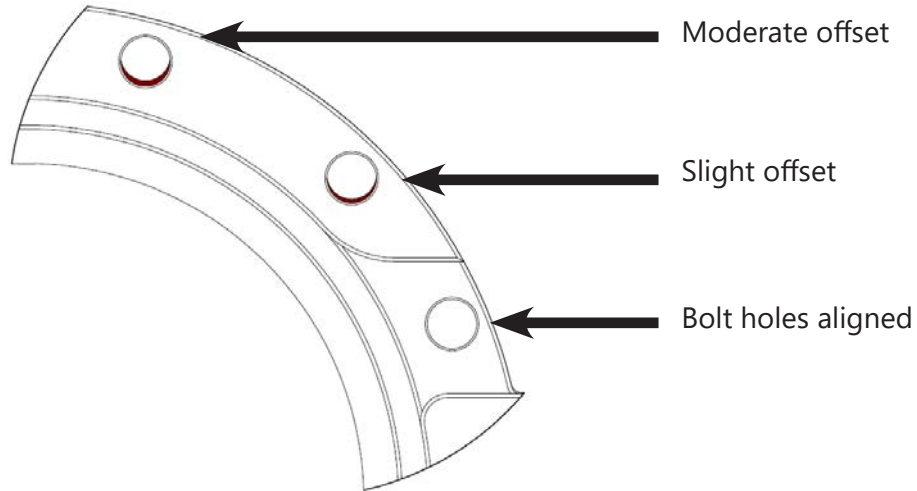

Fig. 10.6.3 Housing segment bolt hole offset (Pin 1 alignment)

5. After removing the roll pins, press the housing segments toward the pump centerline until the bolt holes of the intended roll pin location align with the housing segment holes. For larger pump frames, it may be necessary to use a rubber mallet to aid in this process.
6. With the top and bottom housing segments aligned with the desired pin location on the flange ring and quench chamber, reinsert the roll pins into Pin Location 2 or 3. Note: some pump assemblies feature multiple sets of housing segments; roll pins do not need to be adjusted at these locations.
7. With the roll pins replaced, check the clearance between the lobe tips and housing segments; this clearance should be no less than 0.002 in. Recommended/acceptable clearances will vary by applications; contact LobePro for any questions regarding lobe clearances.

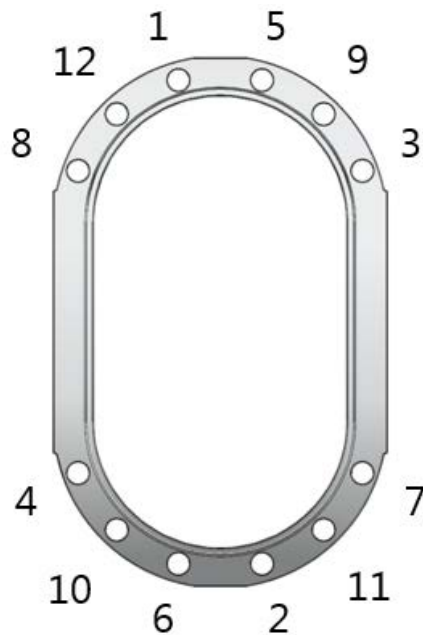

Fig. 10.6.4 Recommended bolt torque pattern

8. Replace the housing segment bolts and fasteners. Hand tighten each bolt and nut in accordance with the pattern given in Fig. 10.6.4, then tighten each bolt to the torques specified in Table 10.5. Each bolt will first be tightened to the value specified as "first pass," then repeat the process using the "second pass" value.

Table 10.5 Housing segment bolt torque specifications

Frame Size	Bolt Size	First Pass Torque	Second Pass Torque
S-frame	M8 x 1.25	12 ft-lbs (16.3 N-m)	20 ft-lbs (27.1 N-m)
M-frame	M10 x 1.5	20 ft-lbs (27.1 N-m)	40 ft-lbs (54.2 N-m)
L- and Lh-frame	M12 x 1.75	35 ft-lbs (47.5 N-m)	75 ft-lbs (101.7 N-m)

9. Replace the O-ring and pump cover. Fasten the cover bolts in a star pattern in accordance with the values in Table 10.5.
10. Reconnect the transition fittings (Section 10.7) and all piping, controls, gauges, and any other equipment removed during this process. Follow all safety instructions in listed in Section 1.0 and verify that all instrumentation and controls are functioning correctly before returning the pump to service.

Note:

Adjusting the housing segments is intended to increase the volumetric efficiency after the lobes and other wear items have worn in. Once the clearances have again exceeded what is necessary for successful operation, the roll pins should be returned to the Pin 1 Location and lobes and wear plates should be replaced.

Volumetric efficiency decreases due to "slip" between the lobes and the housing segments and wear plates, and increases as the clearances between these parts increase. The wear rate of the lobes increases proportionally with the percentage of solids, size of abrasive particles, and the operating speed and differential pressure across the pump. Contact LobePro for recommended operating speeds based upon your setup and application.

10.7 Reinstalling the Transition Fittings

As with the bolts for the pump housing segments, LobePro recommends a specific pattern for fastening the transition fitting bolts to achieve desired sealing at the gasket location. These patterns are given below for each frame size:

S8, M34

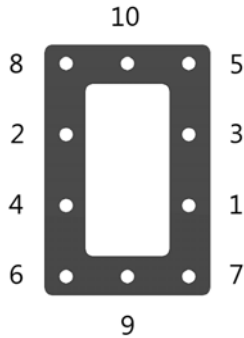

S16, M50, M68

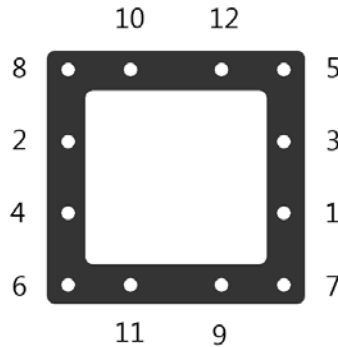

M100

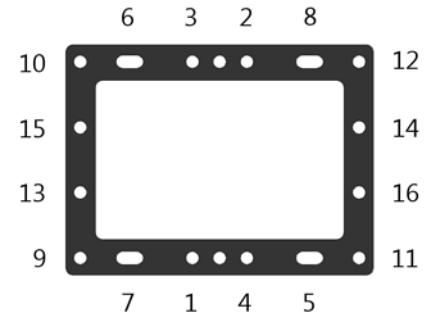

L133, L133h

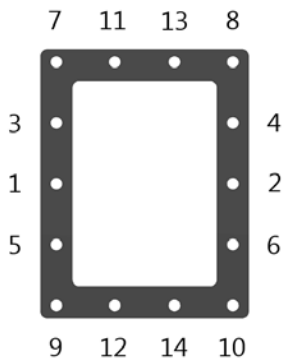

L266, L266h

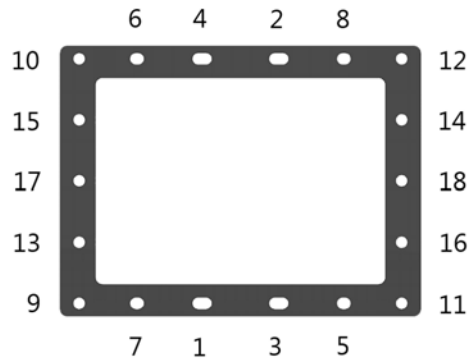

L399, L399h

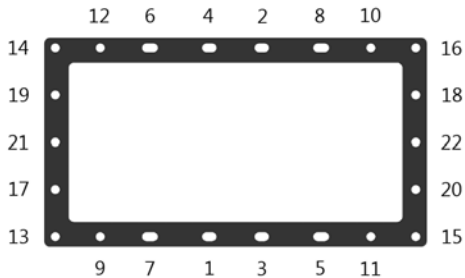

L531, L531h

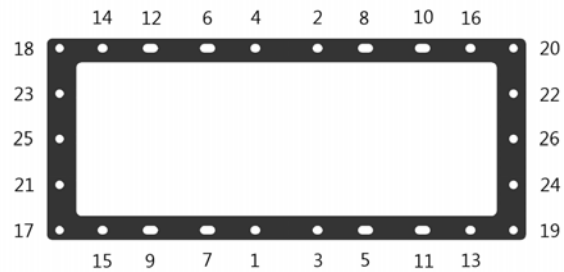

Note: Transition fitting mounting flange and gasket profile may vary by pump frame and materials of construction. Contact LobePro for any questions regarding the installation of transition fittings and gaskets.

As with the housing segment mounting bolts, the bolts for the transition fittings shall be hand tightened, then tightened in a two pass system per the specifications in Table 10.6.

Table 10.6 Transition fitting bolt torque specifications

Frame Size	Bolt Size	First Pass Torque	Second Pass Torque
S-frame	M6 x 1	N/A	8 ft-lbs (10.8 N-m)
M-frame	M10 x 1.5	20 ft-lbs (27.1 N-m)	40 ft-lbs (54.2 N-m)
L- and Lh-frame	M10 x 1.5	20 ft-lbs (27.1 N-m)	40 ft-lbs (54.2 N-m)

Depending on the application and gasket material, transition fitting gaskets may be installed with or without RTV silicone or other sealants. Ensure that any sealants used are compatible with the process fluid, temperature, and other conditions. If sealant is used, ensure that proper cure time is observed, typically 12 to 24 hours.

11 TROUBLESHOOTING

Reported Issue	Common Causes	Corrective Action
Pump does not rotate	Driver fault/failure	Check driver and connections for faults or other signs of failures.
	Coupling/belt/transmission failure	Inspect the coupling or belt assembly for signs of failure.
	Incompressible/large solid locking lobes	Drain pump casing and connections. Check lobes for damage or signs of debris locking the lobes.
Pump/drive shuts down immediately after start-up	Shutdown controls	Check shutdown parameters/controls, adjust as necessary.
	Motor undersized – insufficient for pressure, speed, viscosity, etc.	Reduce operating speed or pressure, or replace motor.
	Excessive pressure generated	Check line for closed valve/blockage. Check operating speeds.
	Tight clearances	New pumps or those with newly installed wear parts (lobes) may see very tight clearances until the lobes wear in. As a first step, loosen the pump cover nuts in quarter-turn increments until the pump can start without leakage.
Pump casing (rapidly) overheating	Pump is running dry (without fluid)	Check line for closed valve/blockage. Ensure pump is primed with fluid.
	Excessive fluid temperature	Check process temperature; adjust controls/system as necessary.
Excessive noise	Excessive vibration	Reduce pump speed/pressure. Tighten frame and mounting bolts. Check alignment. Check lobe clearances. Check solids size and percentage.
	Cavitation	Adjust pump speed and vacuum pressure in suction side of pump. Check pipe size and connections for unnecessary restrictions.
	Strain bolt/lobe failure	Check torque on strain bolt and ensure lobes are free from damage/delamination. If loose, replace per Section 10.
	Excessive pressure	Rapid increases in pressure or pressures well above the pump rating may generate excessive noise.
Leak at housing segment/ transition fitting	Loose bolt due to vibration, assembly error, etc.	Tighten all bolts in accordance with the patterns in Section 10.6 and 10.7. Check gasket(s) and O-ring(s) for signs of damage. Contact LobePro if leak persists.
Quench chamber losing oil	Drain hose assembly defective	Check or replace drain hoses. Tighten all plugs.
	Mechanical seal failure	Pressure test seal assembly per Section 10.5 and replace seal/seal components accordingly.
	Lip seal / secondary O-ring failure	Pressure test seal assembly per Section 10.5 and replace seal/seal components accordingly.
	Pump periphery leak	Inspect/tighten all casing connections and plugs.
Quench chamber temperature high	Oil level is too low	Fill oil to level of sight glass.
	Incorrect oil used	Use recommended oil per Section 8.
	Pump is run dry	Check line for closed valve/blockage. Ensure pump is primed with fluid.
	Quench chamber oil contaminated	Drain/flush/refill quench chamber and gear housing oil.

Reported Issue	Common Causes	Corrective Action
Pump is not generating correct flow/pressure	Pump is not operating	Ensure driver and transmission/coupling are operational and pump is not locked up.
	Pump speed is too low	Check operating speed/controls
	Leak in piping	Check suction and discharge piping for leaks
	Pressure gauge/instrumentation defective	Inspect/replace instrumentation
	Loss of suction/vacuum pressure	Check suction piping for leaks
	Pump is run dry	Check line for closed valve/blockage. Ensure pump is primed with fluid.
	Lobe damaged/delaminated	Inspect lobes for signs of damage; replace accordingly.
	Lobe/wear plates/housing worn	Excessive clearances have reduced flow/pressure generation; adjust or replace parts per Section 10.
	Defective pressure relief valve/setting	Inspect/adjust/replace pressure relief valve
Excessive pressure	Pump efficiency reduces with pressure. Ensure that the pump is operating at the rated pressure.	
Gear housing oil contaminated	Shaft O-ring failure	Replace shaft O-rings per Section 10. Pressure test seal assembly.
	Mechanical seal failure (quench contaminated)	Pressure test seal assembly per Section 10.5 and replace seal/seal components accordingly.
	Moisture ingress	Check tightness of drain plugs, vents, hoses, and sight glasses. Drain and refill gear housing.
Gear housing losing oil	Drain hose assembly defective	Check or replace drain hoses. Tighten all plugs.
	Oil level decreases during operation	Splash lubrication causes the oil level to decrease during operation. Add additional oil to compensate.
Gear housing oil foaming	Gear housing oil level too high	Drain excess oil until at level of sight glass.
	Incorrect oil used	Use recommended oil per Section 8.
	Expected due to splash lubrication	Some foaming/bubbling is expected due to splash lubrication.
	Possible contamination	Drain/flush/refill gear housing oil.
Gear housing temperature high	Standard operation	Gear housing will commonly run 20-30 °F above the application temperature.
	Oil level is too low	Fill oil to level of sight glass.
	Incorrect oil used	Use recommended oil per Section 8.
	Pump is run dry	Check line for closed valve/blockage. Ensure pump is primed with fluid.
	Gear housing oil contaminated	Drain/flush/refill gear housing oil.

12 LARS SEAL TROUBLESHOOTING GUIDE

The best ways to prevent seal failure are to carefully follow the steps detailed in this manual and to assess and monitor any risks in the process/application which may compromise the seal assembly. This may take the form of shutdown switches for temperature, pressure, vibration, or flow, or specialized start-up and shutdown procedures. When does occur or is suspected, the following guide can assist in basic troubleshooting. For further troubleshooting, contact LobePro to discuss your application in greater detail.

Reported Issue	Common Causes	Corrective Action
Gear housing oil contaminated	<p>Failure of shaft O-rings:</p> <ul style="list-style-type: none"> • Damage resulting from abrasion • Improper installation/missing • Incompatible materials • Excessive Vibration <p>Other possible causes:</p> <ul style="list-style-type: none"> • Result of continued operation after contamination of quench chamber • Over pressurization • Strain bolt failure <p>Moisture ingress from shaft lip seal or drain/fill plugs</p>	<p>Replace shaft O-rings: S-frame item no. 50 M-, L-, Lh-frame item no. 31</p> <p>Check strain bolt tightness</p> <p>Check tightness of external casing plugs and lip seal integrity</p>
Quench chamber oil contaminated	<p>Mechanical seal failure:</p> <ul style="list-style-type: none"> • Damage or failure of the face seals or O-rings • Incompatible materials • Damage resulting from abrasion • Over pressurization • Excessive vibration • Excessive suction pressure/cavitation <p>Excessive heat/dry running</p>	<p>Replace mechanical face seals and O-rings:</p> <ul style="list-style-type: none"> • S-frame item no. 39, 43, 44, 49 • M-, L-, Lh-frame item no. 21, 26, 27 <p>Install sensor or shutdown switch to monitor:</p> <ul style="list-style-type: none"> • High pressure • High temperature • Vibration • Flow
Quench chamber and gear housing oil communicating; no contamination	<p>Lip seal failure/defect or failure of base O-ring</p> <ul style="list-style-type: none"> • Improper installation/missing • Incompatible lubrication/lack of lubrication • High temperature <p>Quench/seal not thoroughly cleaned after maintenance/previous failure</p>	<p>Replace secondary seal O-rings and lip seal</p> <ul style="list-style-type: none"> • S-frame item no. 39, 41, 49 • M-, L-, Lh-frame item no. 21, 23 <p>Check rating/compatibility of lubricant</p> <p>Install temperature switch or sensor</p>

Reference pump specification sheets and bill of materials for part numbers listed above.



For all other questions about repair and maintenance procedures not listed or included in this manual, please visit www.lobepro.com or contact us at:

LobePro, LLC
2610 Sidney Lanier Drive
Brunswick, GA 31525
Tel. (912) 466-0304
Fax. (912) 466-0086
www.lobepro.com
info@lobepro.com