

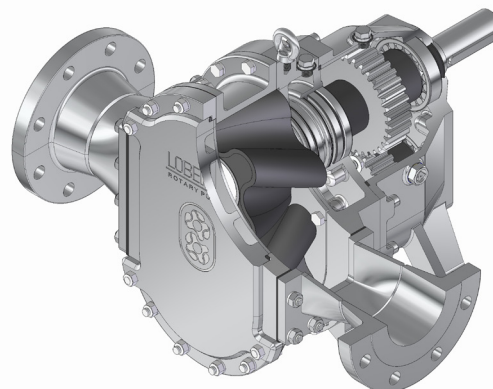

L266d



Positive Displacement Rotary Lobe Pumps

SPECIFICATIONS	US	Metric
Rated Capacity:	0-1,330 gpm	0-302 m ³ /h
Displacement (per 100 revolutions):	266 gal (US)	1,003 L
Working Pressure:	125 psi	8.6 bar
Max. Pressure:	150 psi	10.3 bar
Starting Torque:	3,857 in lbf	436 N m
Rated Speed:	0-500 RPM**	0-500 RPM**
Shaft Diameter:	2.5"	63 mm
Flange Connection	ANSI 8"	DN 200
Weight:	693 lbs	315 kg
Solids Handling		
Spherical Compressible	3"	76 mm
Spherical Hard*	1/8"	3 mm

* Larger hard solids will pass through but may cause damage.

MODEL >	GL266d	SL266d	CL266d
Service	General Use	Sludge, Mud and Slurries	Chemical/Corrosive
Rotary Lobes			
Elastomer	NBR	NBR	FKM/Viton
Lobe Profile	Helix	Helix	Helix
Number of lobe wings	4	4	4
Core	ASTM A48	ASTM A48	ASTM A48
Sealing			
O-rings	NBR	NBR	FKM/Viton
Oil seals	NBR Option HNBR	NBR Option HNBR	FKM/Viton
Cartridge Seals			
Mechanical Seal	Duronit	Duronit	Silicon Carbide
Seal Holders	Mild Steel coated with Electroless Nickel	Mild Steel coated with Electroless Nickel	Stainless Steel 316
Housing Segments**			
Medium touched	Class 30 Grey Iron	AGI-600 Austempered Grey Iron	Stainless Steel 316
Wear Plates			
Medium touched	A36 Steel	AR500 Steel (Brinell 500)	Stainless Steel 316
Shaft			
Medium Untouched	AISI 4140 Steel	AISI 4140 Steel	AISI 4140 Steel, Electroless Nickel Coated
Quench Chamber			
Medium touched	ASTM A48 rust primed	ASTM A48 rust primed	ASTM A48 Electroless Nickel Coated
Gear Housing			
Casting	ASTM A48	ASTM A48	ASTM A48
Bolts			
Medium touched	Steel ASTM F568/ISO 898/I	Steel ASTM F568/ISO 898/I	Stainless Steel DIN 931 A2-A4
Bolts- Strain Bolt			
Medium untouched	ASTM A574M-12.9 Zinc Plated	ASTM A574M-12.9 Zinc Plated	ASTM A574M-12.9 Electroless Nickel coated
Gears			
Medium untouched	AGMA Class 9 SAE 1045 steel	AGMA Class 9 SAE 1045 steel	AGMA Class 9 SAE 1045 steel
Pressure Disc			
Medium touched	A36 Steel	A36 Steel	Stainless Steel 316
Bolt Circle			
Medium touched	A36 Steel	A36 Steel	Stainless Steel 316

NOTE: A wide range of optional materials are available for each model. Above specs are for standard builds. Consult Factory for other variations.

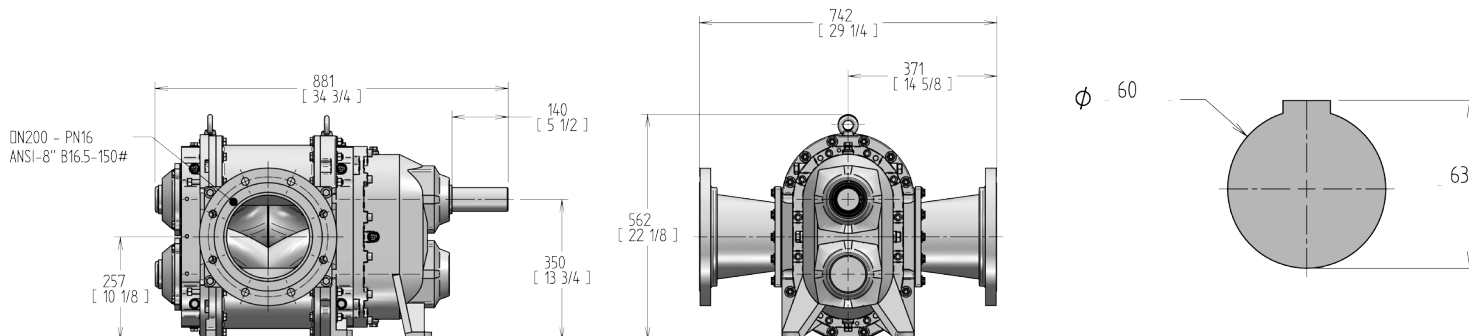

L266d CURVES

Performance Curve

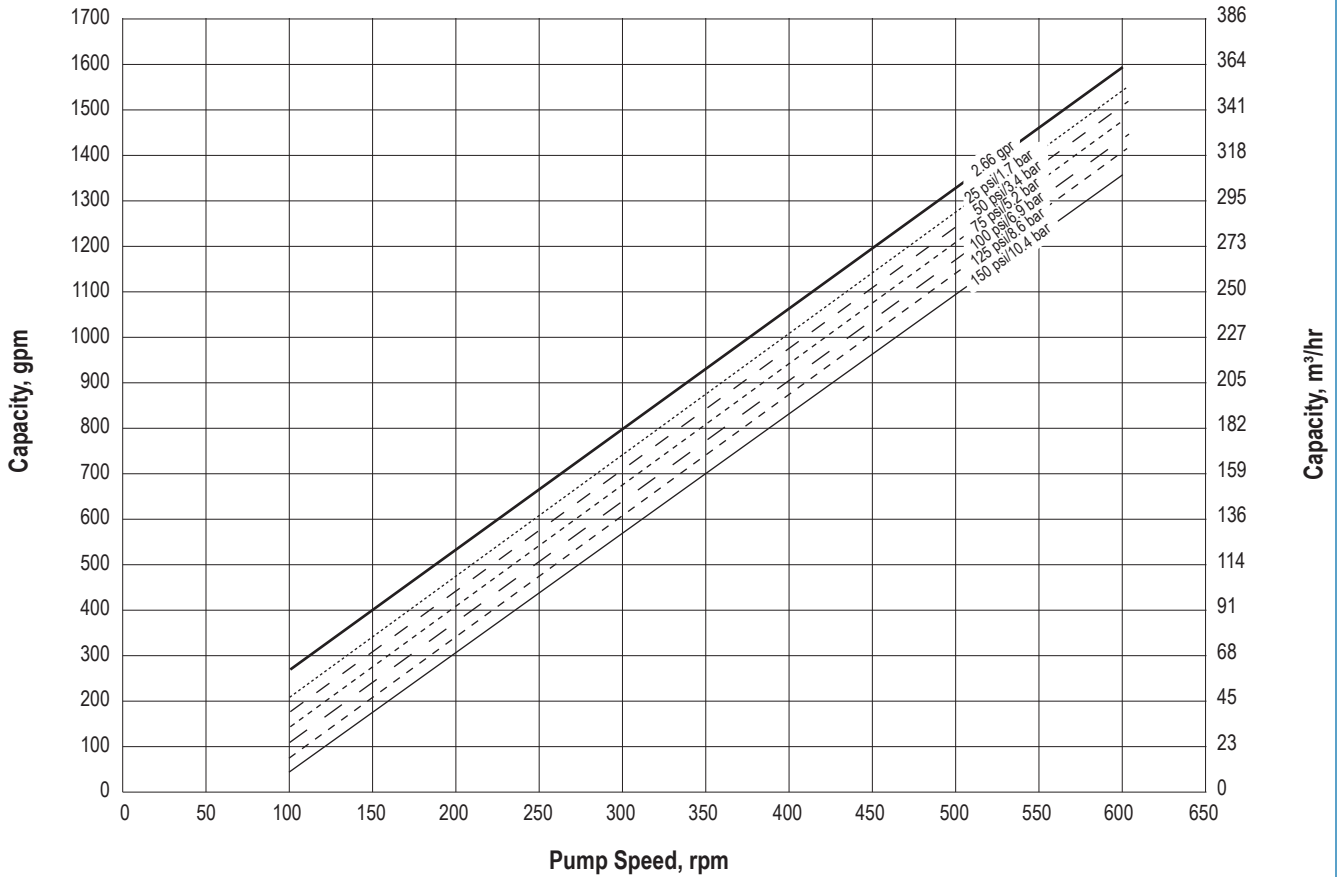

Horsepower Requirements

